

● Description

The KP1510 series consists of GaAlAs Light emitter diode and an integrated. This unit is 8-lead DIP package. KP1510 series is suitable for gate driving circuit of IGBT or power MOSFET.

● Schematic

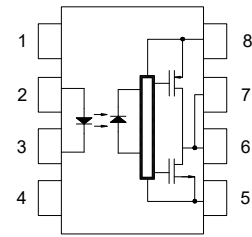

- | | |
|------------|------------------------|
| 1. N.C. | 5. GND |
| 2. Anode | 6. Vo (Voltage Output) |
| 3. Cathode | 7. Vo (Voltage Output) |
| 4. N.C. | 8. Vcc |

● Features

1. High noise immunity characterized by 25kV/ μ s
minimum common mode rejection(CM_R)at $V_{CM}=1500V$
2. 2.5A maximum peak output current
3. $I_{CC} = 5mA$ maximum supply current
4. Wide supply voltage range from 15V to 30V
5. Fast power switching application
 - 250ns max. propagation delay
 - 100ns max. P_{WD} protection scheme
6. Under Voltage Lock-Out (UVLO) with hysteresis
7. Industrial temperate range: $-40^{\circ}C$ to $110^{\circ}C$
8. MSL class 1
9. Agency Approvals:
 - UL Approved (No. E169586): UL1577
 - c-UL Approved (No. E169586)
 - VDE Approved (No. 40020973): DIN EN60747-5-5

● Applications

- Industrial inverters
- Switch mode power supply
- AC/Brushless DC motor drives
- IGBT/Power MOSFET gate drive

● Truth Table

LED	OUTPUT	Q1	Q2
ON	HIGH LEVEL	ON	OFF
OFF	LOW LEVEL	OFF	ON

* The use of a 0.1 μ F bypass capacitor must be connected between pins 8 and 5 is recommended.

● **Outside Dimension**

Unit : mm

1. Dual-in-line type

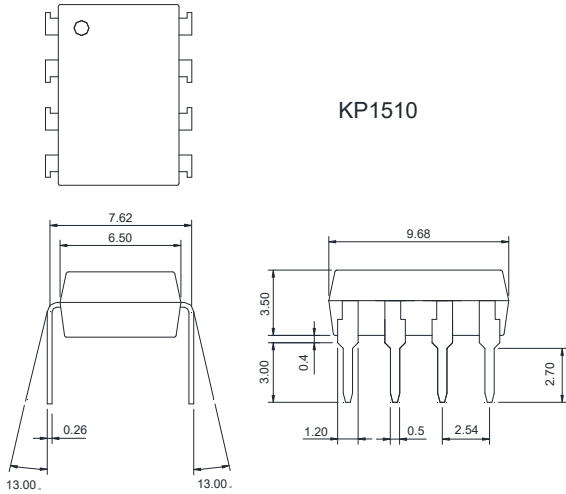

2. Surface mount type

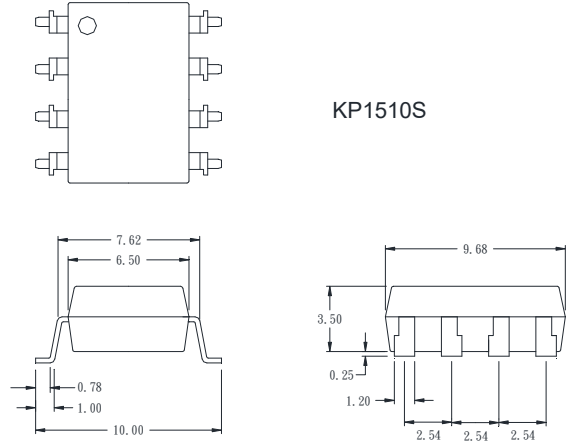

3. Long creepage distance type

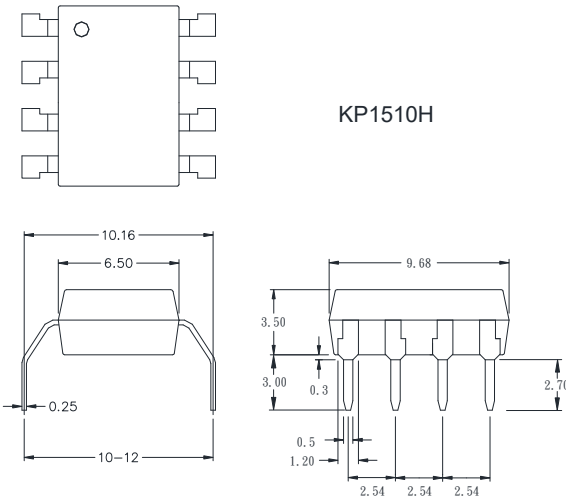

4. Long creepage distance for surface mount type

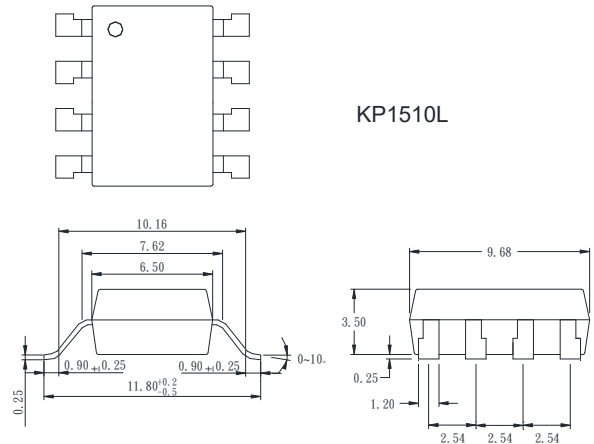

TOLERANCE: ±0.2mm

● **Device Marking**

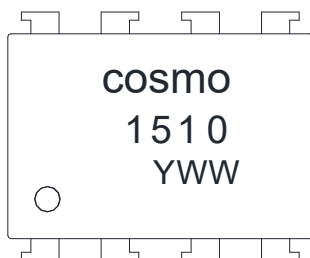

Notes:

cosmo
1510
YWW Y: Year code / WW: Week code

● Absolute Maximum Ratings

(Ta = 25°C)

Parameter	Symbol	Rating	Unit
Storage temperature	T _{STG}	-55 to +125	°C
Operating temperature	T _{OPR}	-40 to +110	°C
Junction temperature	T _J	-30 to +125	°C
Lead wave solder temperature	T _{SOL}	260 for 10 Secs	°C
Average input current	I _{F(AVG)}	25	mA
Peak transient forward current ⁽¹⁰⁾	I _{F(PEAK)}	1	A
Operating frequency ⁽¹¹⁾	f	50	KHz
Reverse input voltage	V _R	5	V
Peak output current ⁽¹⁾	I _{O(PEAK)}	2.5	A
Supply voltage	V _{CC} -V _{EE}	0 to 30	V
		TA ≥ 90°C	
Peak output voltage	V _{O(PEAK)}	0 to V _{CC}	V
Input signal rise and fall time	t _{R(IN)} – t _{F(IN)}	500	ns
Input power dissipation ⁽²⁾⁽⁴⁾	P _{DI}	45	mW
Output power dissipation ⁽³⁾⁽⁴⁾	P _{DO}	250	mW

● Recommended Operating Conditions

Parameter	Symbol	Rating	Unit
Ambient operating temperature	T _A	-40 to +110	°C
Power supply	V _{CC} -V _{EE}	15 to 30	V
Input current (On)	I _{F(ON)}	7 to 16	mA
Input voltage (Off)	V _{F(OFF)}	-3.6 to 0.8	V

● Isolation Characteristics

Parameter	Symbol	Rating	Min.	Typ.	Max.	Unit
Input-output isolation voltage	V _{ISO}	V _A =25°C, R.H.<50%, t-1.0min, I ₁₋₀ ≤ 10uA, 50HZ ⁽⁵⁾⁽⁶⁾	5000	—	—	V _{RMS}
Isolation resistance	R _{ISO}	V ₁₋₀ =500V ⁽⁵⁾	10 ¹¹	—	—	Ω
Isolation capacitance	C _{ISO}	V ₁₋₀ =0V, Freq=1.0MHz ⁽⁵⁾	—	—	1	pF

● Electrical Characteristics

(Ta = 25°C)

Parameter	Symbol	Test Condition	Min.	Typ.	Max.	Unit	
Input forward voltage	V_F	$I_F=10\text{mA}$	1.0	—	1.8	V	
Temperature coefficient of forward voltage	$\Delta (V_F/\Delta T_A)$		—	-1.4	—	mV/°C	
Input reverse breakdown voltage	BV_R	$I_R=10\mu\text{A}$	5	—	—	V	
Input capacitance	C_{IN}	$f=1\text{MHz}, V=0$	—	60	—	pF	
Output current	“H” level ⁽¹⁾	I_{OH}	$V_O = V_{CC}-2.5\text{V}$	-0.5	-1.5	-2.5	A
			$V_O = V_{CC}-4\text{V}$	-2.0	—	-2.5	
	“L” level ⁽¹⁾	I_{OL}	$V_O = V_{EE}+2.5\text{V}$	0.5	2.0	2.5	A
			$V_O = V_{EE}+4\text{V}$	2.0	—	2.5	
Output voltage	“H” level	V_{OH}	$I_F = 10\text{mA}, I_O = -100\text{mA}$	$V_{CC}-0.3\text{V}$	$V_{CC}-0.1\text{V}$	—	V
	“L” level	V_{OL}	$I_F = 0\text{mA}, I_O = 100\text{mA}$	—	$V_{EE}+0.1\text{V}$	$V_{EE}+0.3\text{V}$	
Supply current	“H” level	I_{CCH}	$V_O = \text{Open}, I_F = 7 \text{ to } 16\text{mA}$	—	1.7	3.0	mA
	“L” level	I_{CCL}	$V_O = \text{Open}, V_F = -3.0 \text{ to } 0.8\text{V}$	—	2.1	3.0	
Threshold input current	“Output L→H”	I_{FLH}	$I_O = 0\text{mA}, V_O > 5\text{V}$	—	2.3	5.0	mA
Threshold input voltage	“Output H→L”	V_{FHL}	$I_O = 0\text{mA}, V_O < 5\text{V}$	0.7	—	—	V
Under voltage lockout threshold		V_{UVLO+}	$I_F = 10\text{mA}, V_O > 5\text{V}$	11.0	12.3	13.5	V
		V_{UVLO-}	$I_F = 10\text{mA}, V_O < 5\text{V}$	9.0	10.7	12.0	
Under voltage lockout threshold hysteresis		$UVLO_{HYS}$		—	1.6	—	V

● Switching Characteristics

(Ta = 25°C)

Parameter	Symbol	Test Condition	Min.	Typ.	Max.	Unit	
Propagation delay time	“L→H”	I _F =7mA to 16mA R _g =10Ω, C _g =10nF F=10KHz, Duty Cycle=50%	110	130	250	ns	
	“H→L”		110	140	250	ns	
Pulse width distortion t _{PHL} - t _{PLH}	P _{WD}		—	10	100	ns	
Propagation delay difference Between Any Two Parts or Channels (t _{PHL} - t _{PLH}) ⁽⁷⁾	P _{DD} (Skew)		-150	—	150	ns	
Output rise time (10%-90%)	t _r		—	0.1	—	μs	
Output fall time	t _f		—	0.1	—	μs	
UVLO turn-on delay	T _{UVLO ON}		I _F =10mA, V _O >5V	—	0.8	—	μs
UVLO turn-off delay	T _{UVLO OFF}		I _F =10mA, V _O <5V	—	0.6	—	μs
Common mode transient immunity at high level output	C _{MH}		T _A =25°C, V _{CC} =30V, I _F =10mA to 16mA V _{CM} =1500V ⁽⁸⁾	25	35	—	KV / μs
Common mode transient immunity at low level output	C _{ML}		T _A =25°C, V _{CC} =30V, V _F =0V V _{CM} =1500V ⁽⁹⁾	25	35	—	KV / μs

Notes:

1. Maximum pulse width = 10μs, maximum duty cycle = 1.1%
2. Derate linearly above 87°C, free air temperature at a rate of 0.77mW/°C
3. No derating required across temperature range.
4. Functional operation under these conditions is not implied. Permanent damage may occur if the device is subjected to conditions outside these ratings.
5. Device is considered a two terminal device: Pins 2 and 3 are shorted together and Pins 5, 6, 7 and 8 are shorted together.
6. 5,000 VRMS for 1 minute duration is equivalent to 6,000 VACRMS for 1 second duration.
7. The difference between t_{PHL} and t_{PLH} between any two KP1510 parts under same test conditions.
8. Common mode transient immunity at output high is the maximum tolerable negative dV_{cm}/dt on the trailing edge of the common mode impulse signal, V_{cm}, to assure that the output will remain high (i.e. V_O > 15.0V).
9. Common mode transient immunity at output low is the maximum tolerable positive dV_{cm}/dt on the leading edge of the common pulse signal, V_{cm}, to assure that the output will remain low (i.e. V_O < 1.0V).
10. Pulse Width, PW δ 1μs, 300pps
11. Exponential Waveform, I_O(PEAK) ≤ | 2.5A | (≤ 0.3μs)

TYPICAL PERFORMANCE CURVES & TEST CIRCUITS

Fig.1 High output rail voltage vs. Temperature

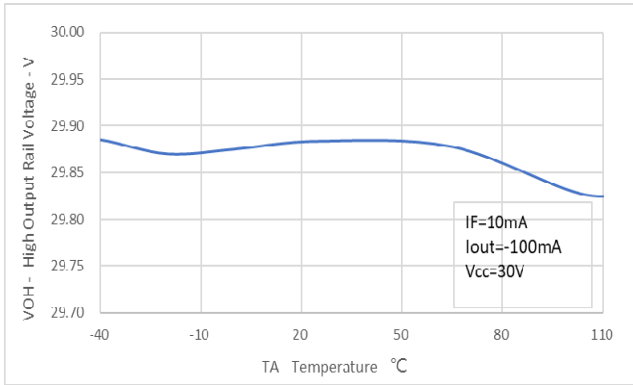

Fig.2 V_{OH} vs. Temperature

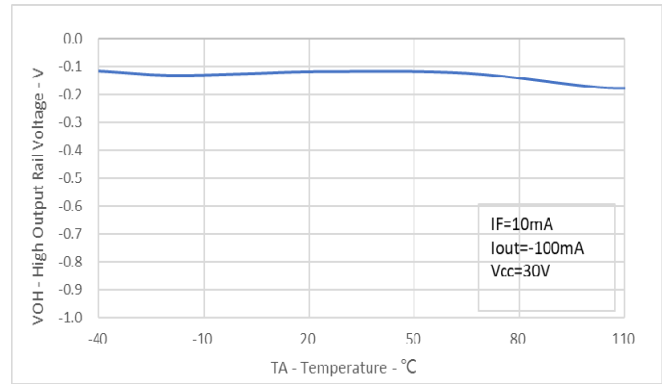

Fig.3 VOL vs. Temperature

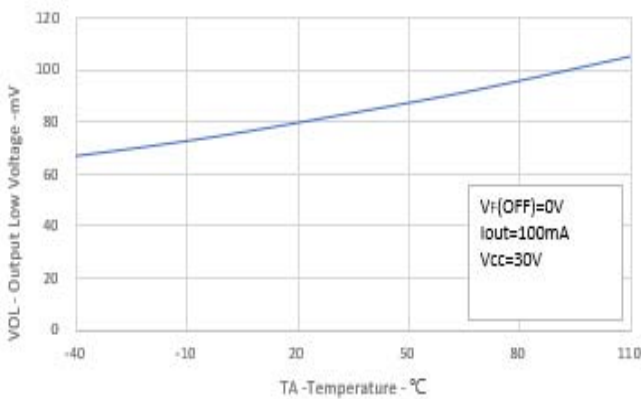

Fig.4 ICC vs. Temperature

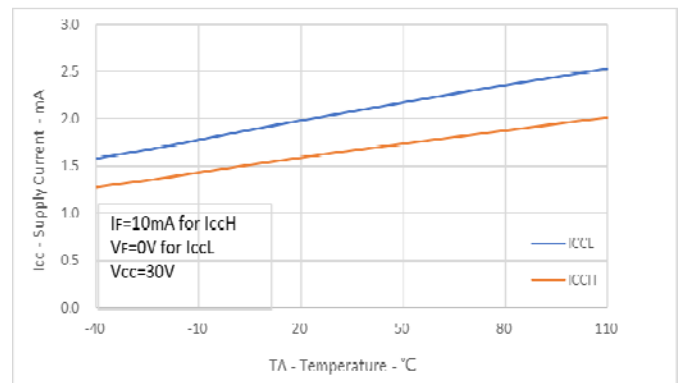

Fig.5 ICC vs. VCC

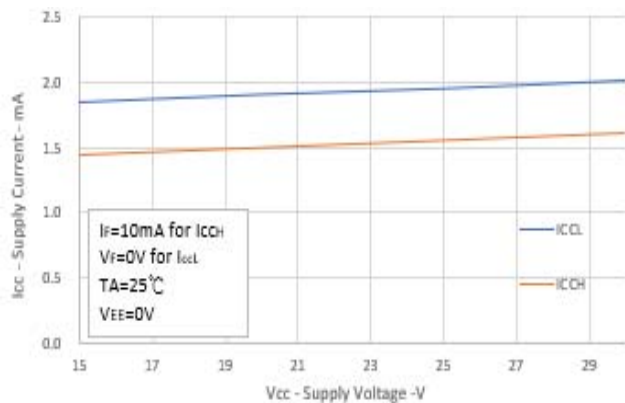

Fig. 6 IFLH Hysteresis

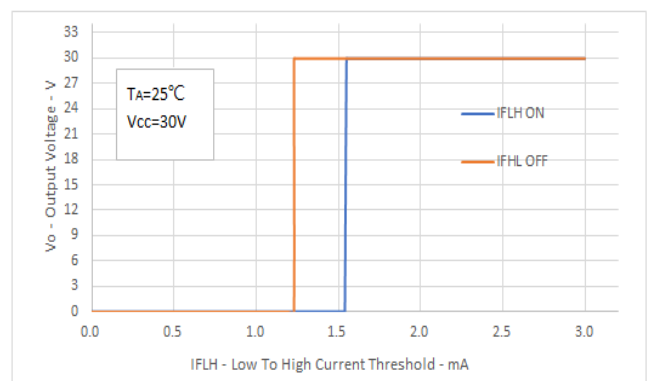

Fig.7 IFLH vs. Temperature

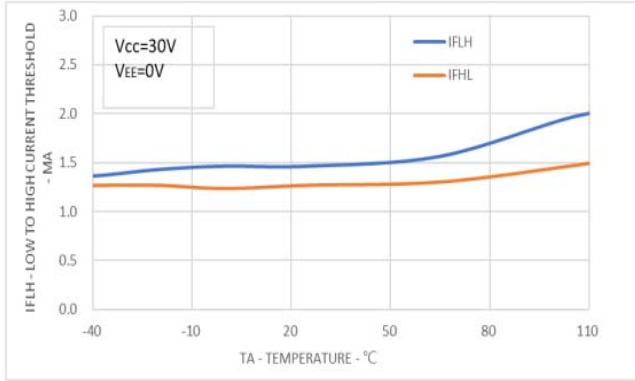

Fig.8 Propagation Delays vs. VCC

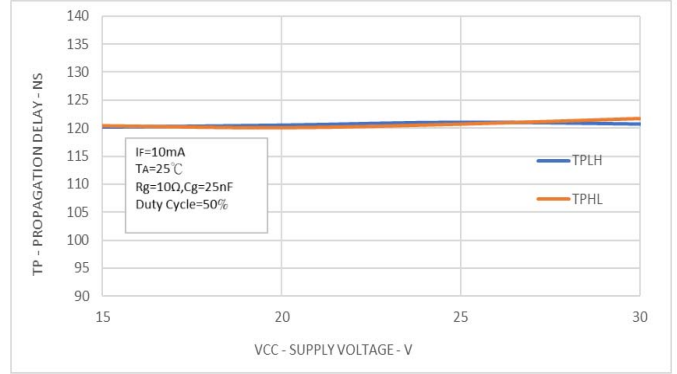

Fig.9 Propagation Delays vs. IF

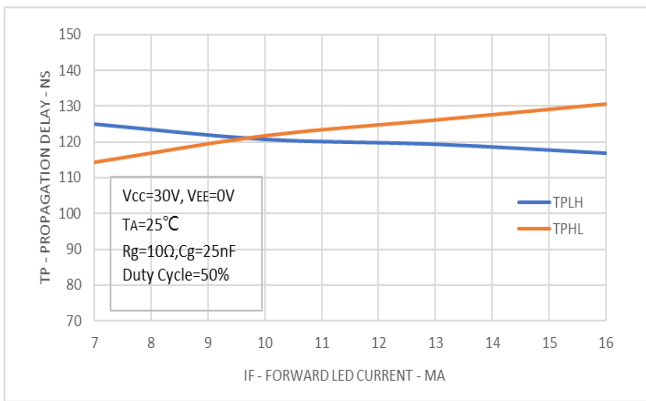

Fig.10 Propagation Delays vs. Temperature

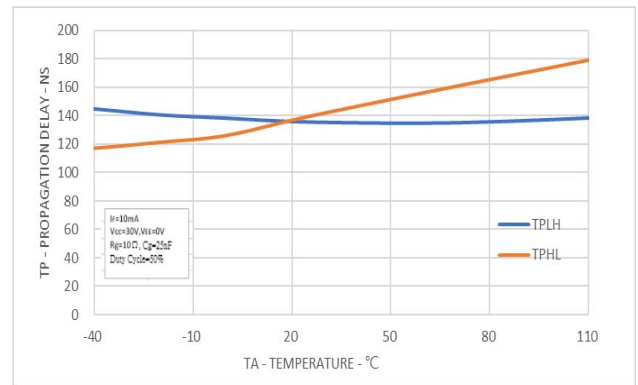

Fig.11 Propagation Delay vs Rg

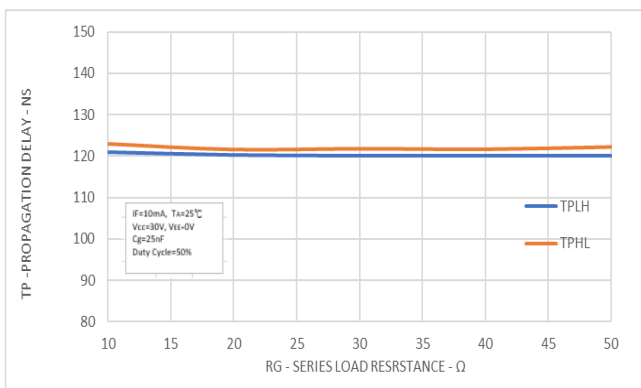

Fig. 12 Propagation Delay vs. Cg

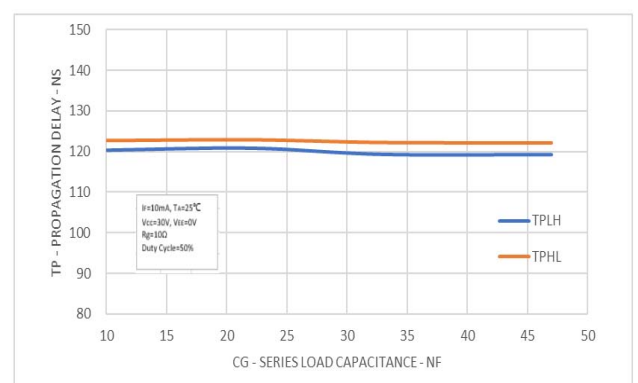
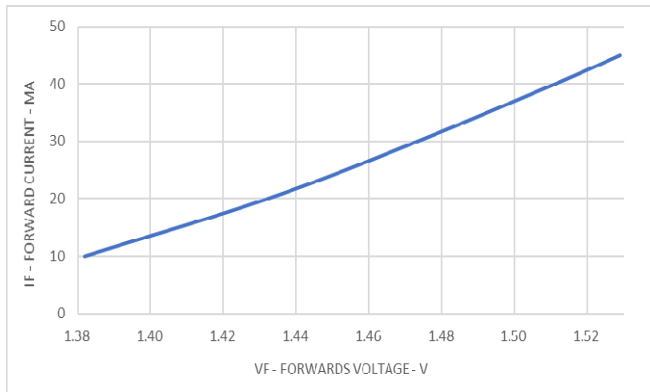

Fig.13 Input Current vs. Forward Voltage



● **Test Circuit**

Fig.11 Top View

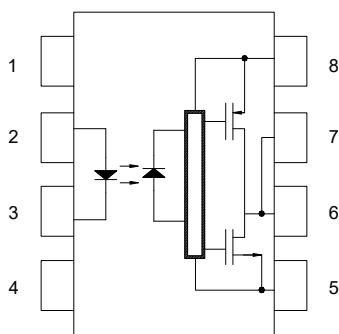

Fig.12 I_{OPL} Measure

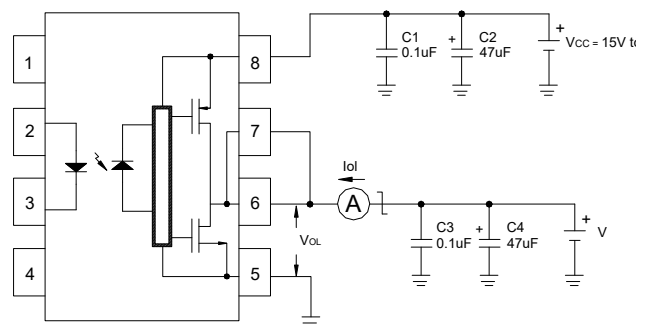

Fig.13 I_{OPH} Measure

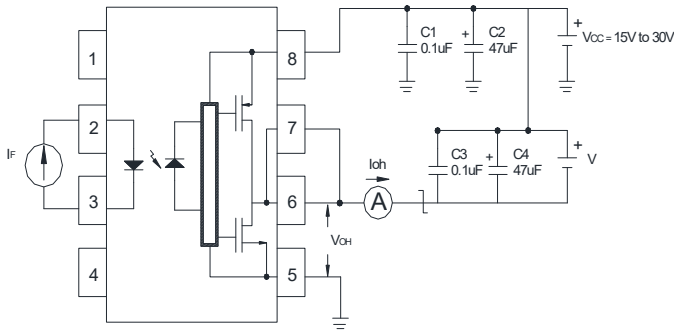

Fig.14 V_{OL} Measure

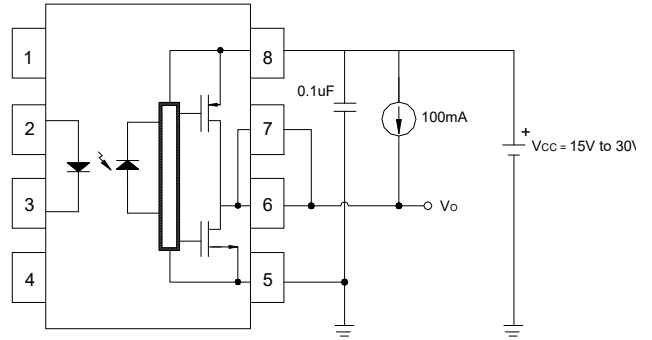

Fig.15 V_{OH} Measure

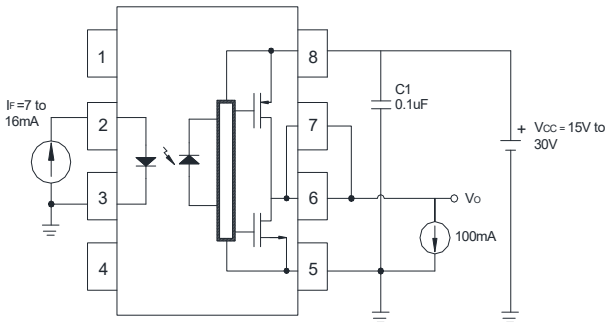

Fig.16 t_{pLH}, t_{pHL}, t_r, t_f Measure

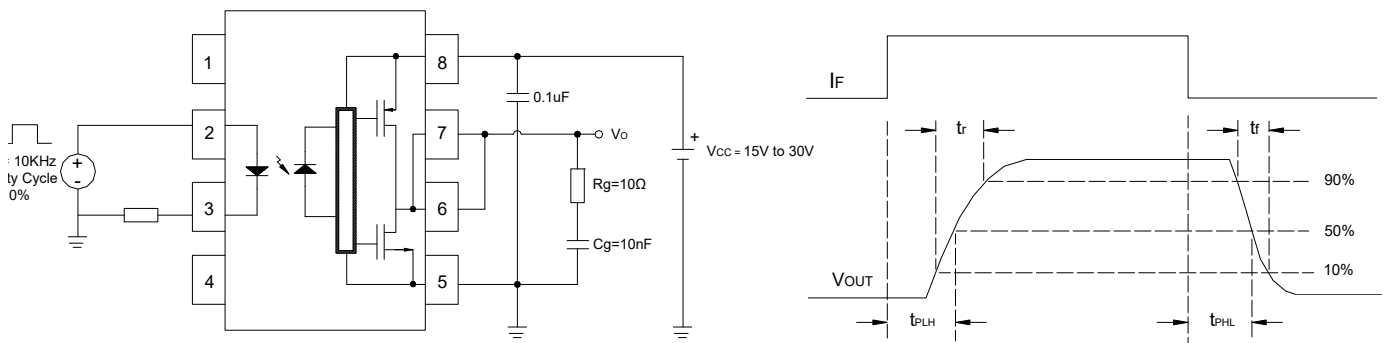
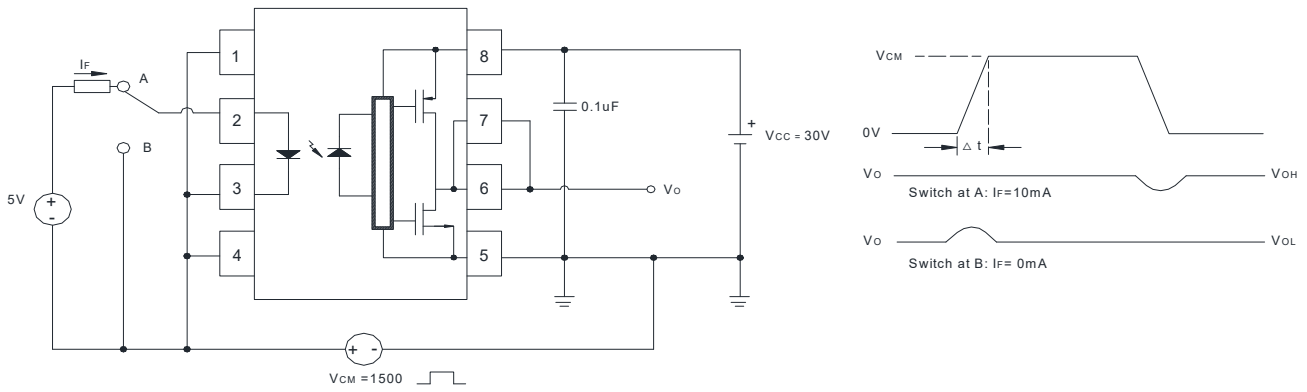

Fig.17 C_{MH} , C_{ML} Measure



* C_{ML} (C_{MH}) is the maximum rate of rise (fall) of the common mode voltage that can be sustained with the output voltage in the low (high) state.

● Recommended Soldering Conditions

(a) Infrared reflow soldering :

- Peak reflow soldering : 260°C or below (package surface temperature)
- Time of peak reflow temperature : 10 sec
- Time of temperature higher than 230°C : 30-60 sec
- Time to preheat temperature from 180~190°C : 60-120 sec
- Time(s) of reflow : Two
- Flux : Rosin flux containing small amount of chlorine (The flux with a maximum chlorine content of 0.2 Wt% is recommended.)

Recommended Temperature Profile of Infrared Reflow

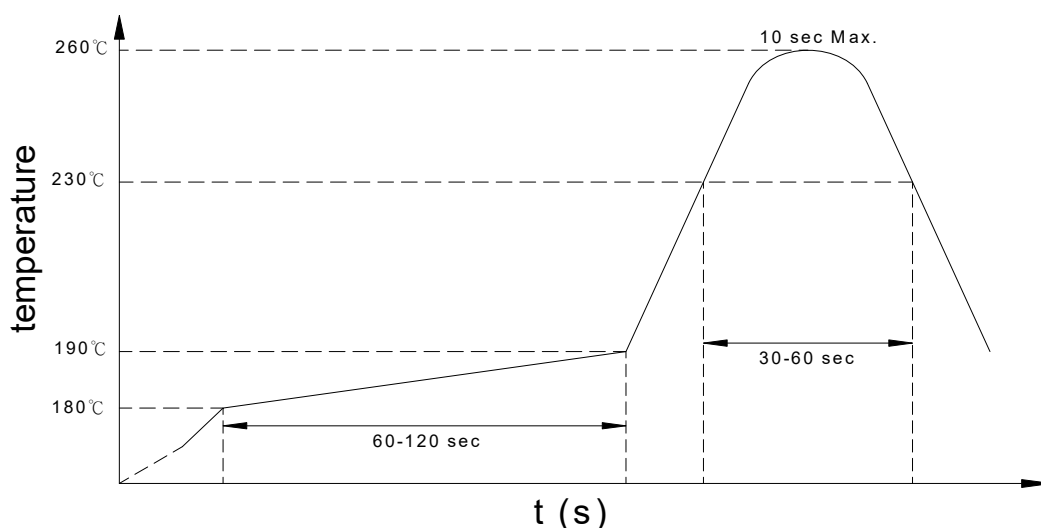

(b) Wave soldering :

- Temperature : 260°C or below (molten solder temperature)
- Time : 10 seconds or less
- Preheating conditions : 120°C or below (package surface temperature)
- Time(s) of reflow : One
- Flux : Rosin flux containing small amount of chlorine (The flux with a maximum chlorine content of 0.2 Wt% is recommended.)

(c) Cautions :

- Fluxes : Avoid removing the residual flux with freon-based and chlorine-based cleaning solvent.
- Avoid shorting between portion of frame and leads.

- **Numbering System**

KP1510 X (Y)

Notes:

KP1510 = Part No.

X = Lead form option (blank · S · H · L)

Y = Tape and reel option (TL · TR · TLD · TRU)

Option	Description	Packing quantity
S (TL)	surface mount type package + TL tape & reel option	1000 units per reel
S (TR)	surface mount type package + TR tape & reel option	1000 units per reel

- **Recommended Pad Layout for Surface Mount Lead Form**

1.Surface mount type

8-pin SMD

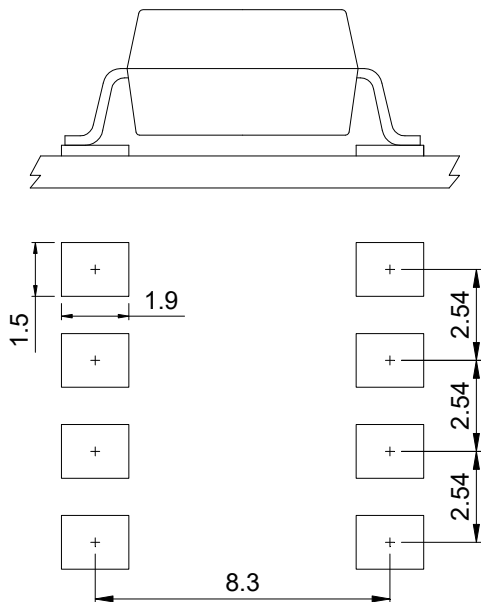

2.Long creepage distance for surface mount type

8-pin L

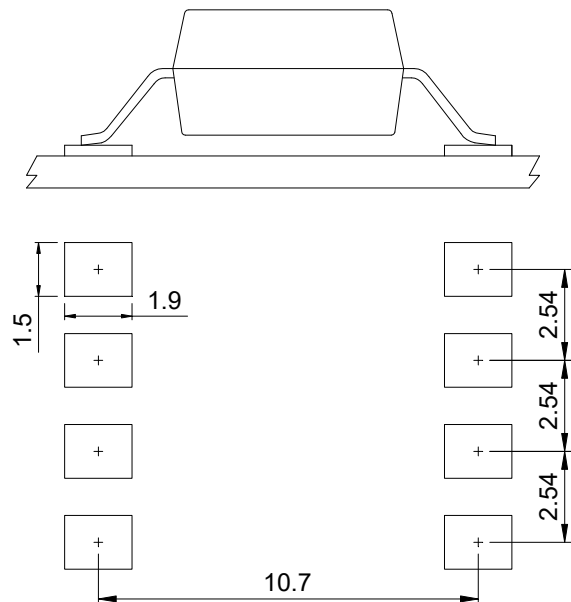

Unit :mm

● 8-pin SMD Carrier Tape & Reel

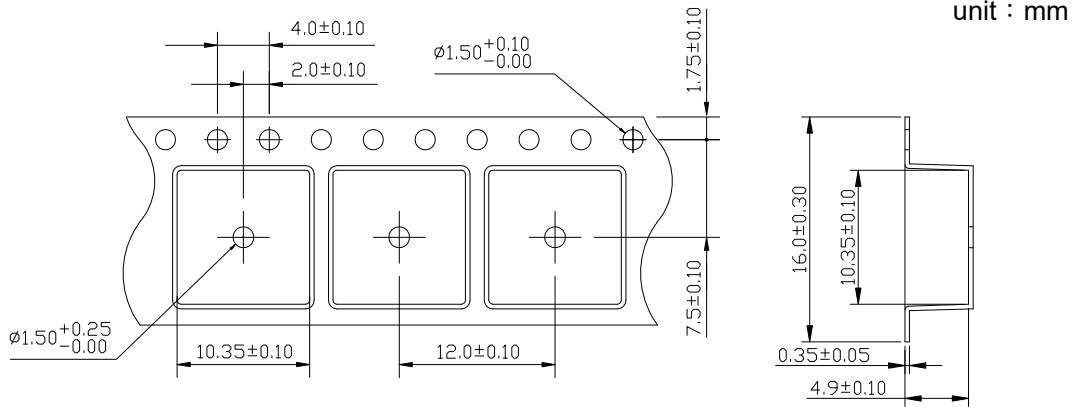

TL

TR

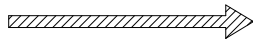
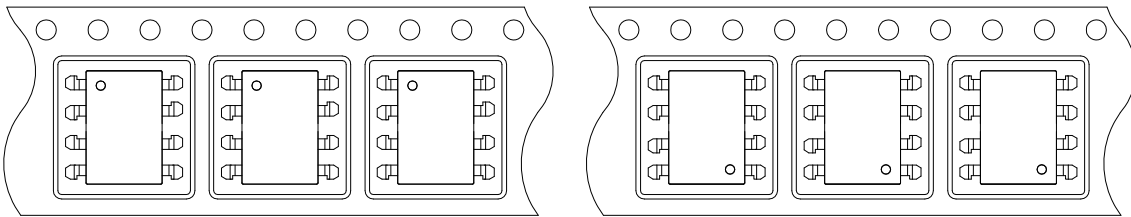

Direction of feed from reel

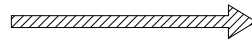

Direction of feed from reel

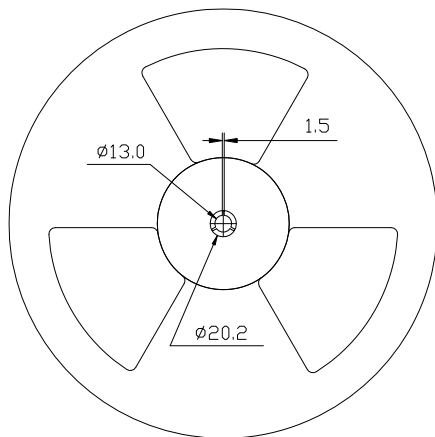

Quantity : 1000pcs/reel

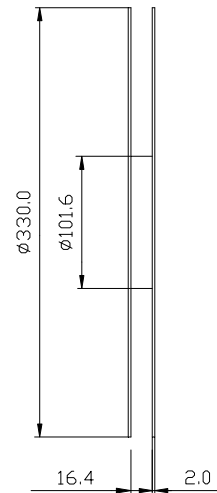

- **Application Notice**

The statements regarding the suitability of products for certain types of applications are based on cosmo's knowledge of general applications of cosmo products. Such statements are not binding statements about the suitability of products for a particular application. It is the customer's responsibility to verify the specifications are suitable for use in a particular application. Customers are solely responsible for all aspects of their own product design or applications. The parameters provided in the datasheet may vary in different applications and performance may vary over time. All operating parameters (including typical parameters) must be validated by customer's technical experts for different applications. cosmo assumes no liability for customer' product design or applications. Product specifications do not expand or otherwise change cosmo's terms and conditions of purchase, including but not limited to the warranty expressed therein.

When using cosmo products, please comply with safety standards and instructions. cosmo has no liability and responsibility to the damage caused by improper use of the instructions specified in the specifications.

cosmo products are designed for use in general electronic equipment such as telecommunications, office automation equipments, personal computers, test and measurement equipments, consumer electronics, industrial control, instrumentation, audio, video.

cosmo devices shall not be used in equipment that requires higher level of reliability and safety, such as nuclear power control equipment, telecommunication equipment(trunk lines), space application, medical and other life supporting equipments, and equipment for aircraft, military, automotive or any other application that can cause human injury or death.

cosmo reserves the right to change the specifications, data, characteristics, structure, materials and other contents at any time without notice. Please contact cosmo to obtain the latest specification.

cosmo disclaim any and all liability for any errors, inaccuracies or incompleteness contained in any datasheet or in any other disclosure relating to any product.