

● Description

The KT0341 series Photocoupler is ideally suited for driving power IGBTs and MOSFETs used in motor control inverter applications and inverters in power supply system. It contains an LED optically coupled to an integrated circuit with a power output stage.

The 3.0A peak output current is capable of directly driving most IGBTs with ratings up to 1200 V/200 A. For IGBTs with higher ratings, the KT341 series can be used to drive a discrete power stage which drives the IGBT gate.

The Photocoupler operational parameters are guaranteed over the temperature range from -40°C ~ +110°C.

● Features

1. 3.0 A maximum peak output current
 2. Rail-to-rail output voltage
 3. 110 ns maximum propagation delay
 4. Under Voltage Lock-Out protection (UVLO) with hysteresis
 5. Wide operating range: 15 to 30 Volts (V_{CC})
 6. Guaranteed performance over temperature -40°C ~ +110°C.
 7. MSL class 1
 8. Agency Approvals:
 - UL Approved : UL1577
 - VDE Approved : DIN EN60747-5-5
- $V_{IORM} = 891V_{peak}$ for KT0341P
 $V_{IORM} = 1140V_{peak}$ for KT0341W

● Applications

- Industrial inverter
- IGBT/Power MOSFET gate drive
- Uninterruptible power supply (UPS)
- AC brushless and DC motor drives
- Switching power suppliers

● Truth Table

LED	$V_{CC}-V_{SS}$ (Turn-ON, +ve going)	$V_{CC}-V_{SS}$ (Turn-OFF, -ve going)	V_o
OFF	0 V to 30 V	0 V to 30 V	Low
ON	0 V to 11.0 V	0 V to 9.5 V	Low
ON	11.0 V to 13.5 V	9.5 V to 12 V	Transition
ON	13.5 V to 30 V	12 V to 30 V	High

Note: A 0.1 μ F bypass capacitor must be connected between Pin 4 and 6.

● Schematic

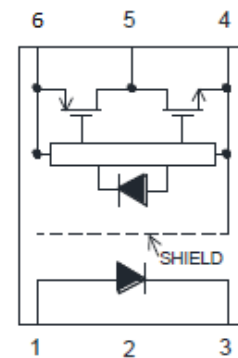

- | | |
|------------|-------------------|
| 1. Anode | 4. V_{SS} |
| 2. N.C. | 5. V_o (Output) |
| 3. Cathode | 6. V_{CC} |

● Outside Dimension

Surface Mount Lead Forming

1. P type

(Unit : mm)

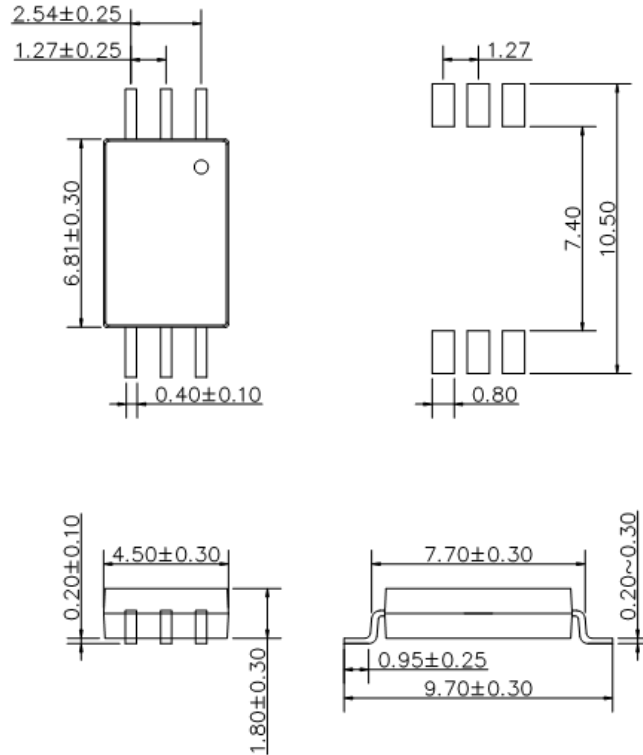

2. W type

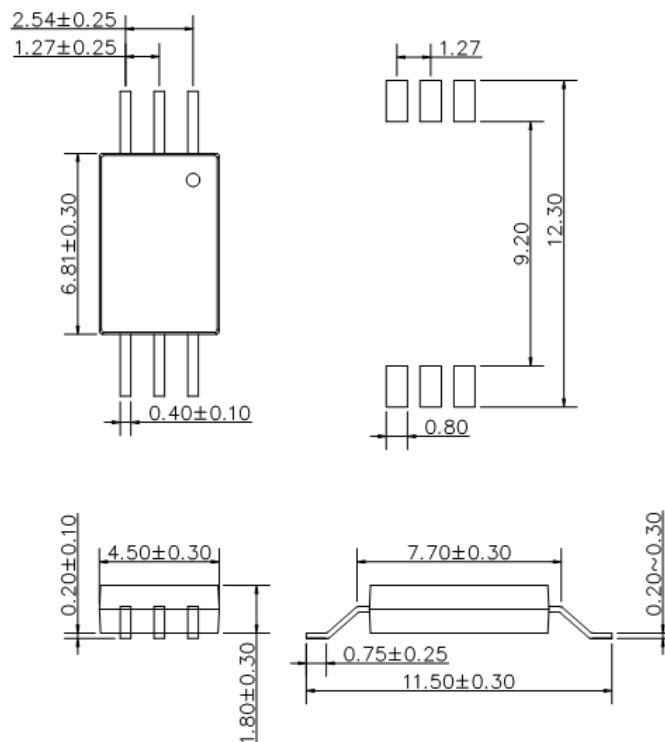

● Device Marking

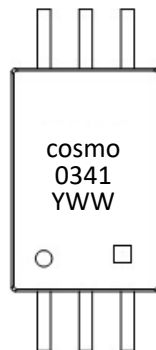

Notes:

COSMO
0341
YWW



Y: Year code / WW: Week code
V or None: VDE Option

● Absolute Maximum Ratings

(Ta = 25°C)

Parameter		Symbol	Rating	Unit
Input	Forward current	I_F	20	mA
	Peak transient forward current (*Note 1)	I_{FPT}	1	A
	Reverse voltage	V_R	5	V
Output	“H” peak output current (*Note 2)	$I_{OH(PEAK)}$	3.0	A
	“L” peak output current (*Note 2)	$I_{OL(PEAK)}$	3.0	A
	Output voltage	$V_{O(PEAK)}$	-0.5~ V_{CC}	V
	Total output supply voltage	$V_{CC}-V_{SS}$	0~35	V
	Junction temperature	T_J	125	°C
Power Dissipation		P_I	45	mW
Output IC Power Dissipation		P_O	700	mW
Operating temperature range		T_{opr}	-40~110	°C
Storage temperature range		T_{stg}	-55~125	°C
Lead soldering temperature (10s)		T_{sol}	260	°C
Isolation voltage (t=1min.,R.H ≤ 40%~60%) (*Note 3,4,5)		V_{ISO}	5000	V

Note: Ambient temperature = 25°C, unless otherwise specified. Stresses exceeding the absolute maximum ratings can cause permanent damage to the device. Exposure to absolute maximum ratings for long periods of time can adversely affect reliability.

*Note1: Pulse width $P_w \leq 1\mu s, 300pps$.

*Note2: Exponential waveform. Pulse width $\leq 10\mu s, f \leq 15kHz$

*Note3: $V_{CC} - V_{SS} = 30V$, unless otherwise specified; all minimum and maximum specifications are at recommended operating condition.

*Note4: Device is considered a two terminal device: pins 1, 2, 3 are shorted together and pins 4, 5, 6 are shorted together.

*Note5: According to UL1577, each photocoupler is tested by applying an insulation test voltage 6000VRMS for one second. This test is performed before the 100% production test for partial discharge.

● Electrical Characteristics

(Ta = 25°C)

Parameter	Symbol	Test Condition	Min.	Typ.	Max.	Unit	
Input forward voltage	V_F	$I_F=10\text{mA}$	1.6	1.9	2.4	V	
Temperature coefficient of forward voltage	$\Delta V_F/\Delta T_a$	$I_F=10\text{mA}$	—	-1.237	—	mV/°C	
Input reverse voltage	BV_R	$I_R=10\mu\text{A}$	5	—	—	V	
Input capacitance	C_{IN}	$V_F=0\text{V}, f=1\text{MHz}$	—	60	—	pF	
Output current (*Note 1)	“H” level	I_{OH}	$V_{CC}=30\text{V}$	$I_F=10\text{mA}$ $V_O=V_{CC}-4$	3.0	—	A
	“L” level	I_{OL}		$I_F=0\text{mA}$ $V_O=V_{SS}+4$	3.0	—	
Output voltage (*Note 2,3)	“H” level	V_{OH}	$I_F=10\text{mA}, I_O=-100\text{mA}$	29.7	29.88	—	V
	“L” level	V_{OL}	$I_F=0\text{mA}, I_O=100\text{mA}$	—	0.1	0.3	
Supply current	“H” level	I_{CCH}	$V_{CC}=30\text{V}, I_F=10\text{mA},$ $V_O=\text{Open}, R_g=10\Omega,$ $C_g=6\text{nF}$	—	1.7	3	mA
	“L” level	I_{CCL}	$V_{CC}=30\text{V}, I_F=0\text{mA},$ $V_O=\text{Open}, R_g=10\Omega,$ $C_g=6\text{nF}$	—	2.11	3	
Threshold input current	“Output L→H”	I_{FLH}	$V_O > 5\text{V}, I_O=0\text{A}$	—	0.9	2	mA
Threshold input voltage	“Output H→L”	V_{FHL}	$V_{CC}=30\text{V}, V_O < 5\text{V}$	0.8	—	—	V
Under Voltage Lockout Threshold		V_{UVLO+}	$V_O > 5\text{V}, I_F = 10\text{mA}$	11.0	12.6	13.5	V
		V_{UVLO-}	$V_O < 5\text{V}, I_F = 10\text{mA}$	9.5	11.2	12.0	V
UVLO Hysteresis		$UVLO_{HYS}$	—	—	1.4	—	V
Supply voltage		V_{CC}		15	—	30	V
Resistance (input-output)		R_{I-O}	$V_{I-O}=500\text{VDC}$	—	10^{12}	—	Ω

All Typical values at Ta = 25°C and $V_{CC} - V_{SS} = 30\text{V}$, unless otherwise specified; all minimum and maximum specifications are at recommended operating condition.

Note 1: Maximum pulse width = 10 μs .

Note 2: In this test V_{OH} is measured with a DC load current. When driving capacitive loads, V_{OH} will approach V_{CC} as I_{OH} approaches zero amps.

Note 3: Maximum pulse width = 1 ms.

● **Recommend Operation Conditions**

Parameter	Symbol	Min.	Max.	Unit
Operating Temperature	T_A	-40	110	°C
Supply Voltage	V_{CC}	15	30	V
Input Current (ON)	$I_{F(ON)}$	7	16	mA
Input Voltage (OFF)	$V_{F(OFF)}$	-3.0	0.8	V

● **Switching Characteristics**

(Ta = 25°C)

Parameter	Symbol	Test Condition	Min.	Typ.	Max.	Unit
Propagation delay time	"L→H"	$R_g=10\ \Omega$, $C_g=25\ nF$, $I_F=10mA$, $f=10kHz$, Duty Cycle =50% $V_{CC}=30V$	—	61.3	110	ns
	"H→L"		—	74.5	110	
Pulse Width Distortion	PWD		—	22	70	
Propagation Delay Difference Between Any Two Parts	PDD ($t_{PHL} - t_{PLH}$)		-100	—	+100	
Output rise time	t_r		—	20	—	
Output fall time	t_f		—	15	—	
Common mode transient immunity at high level output (*Note 1,2)	CM_H		$V_{CM}=1KV$, $I_F=7\sim 16mA$ $V_{CC}=30V$, $T_a=25^\circ C$	20	40	—
Common mode transient immunity at low level output (*Note 1,3)	CM_L	$V_{CM}=1KV$, $I_F=0mA$ $V_{CC}=30V$, $T_a=25^\circ C$	20	40	—	KV / μs

All Typical values at $T_a = 25^\circ C$ and $V_{CC} - V_{SS} = 30\ V$, unless otherwise specified; all minimum and maximum specifications are at recommended operating condition.

Note 1: Pin 2 needs to be connected to LED common.

Note 2: Common mode transient immunity in the high state is the maximum tolerable dV_{CM}/dt of the common mode pulse, V_{CM} , to assure that the output will remain in the high state (meaning $V_O > 15.0V$).

Note 3: Common mode transient immunity in a low state is the maximum tolerable dV_{CM}/dt of the common mode pulse, V_{CM} , to assure that the output will remain in a low state (meaning $V_O < 1.0V$).

Fig.1 High output rail voltage vs. Temperature

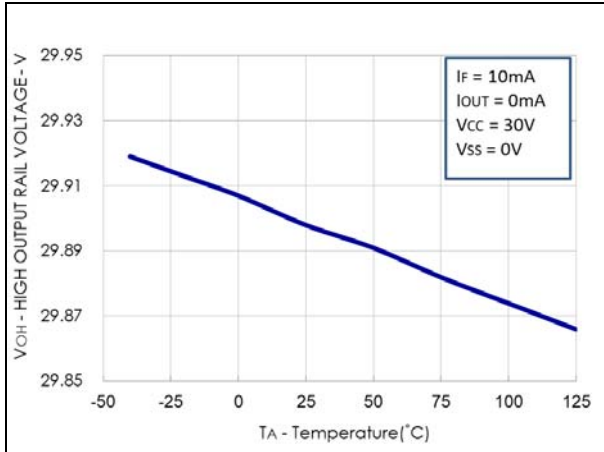

Fig.2 V_{OH} vs. Temperatures

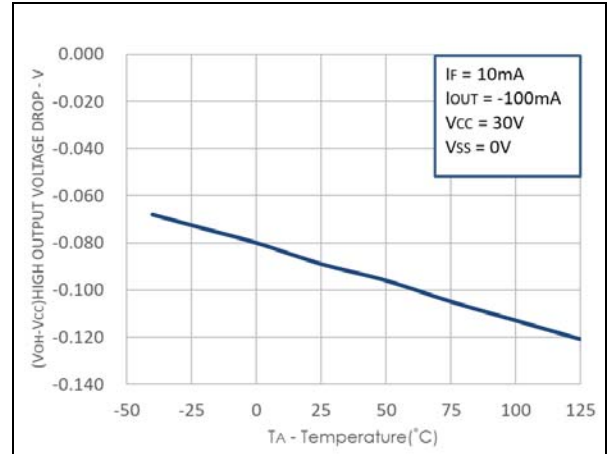

Fig.3 V_{OL} vs. Temperature

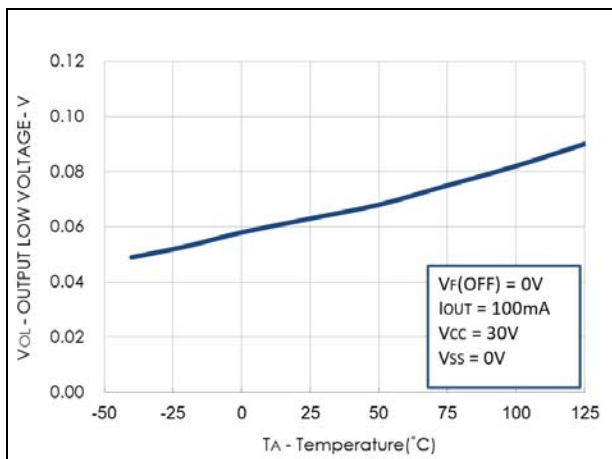

Fig.4 I_{CC} vs. Temperature

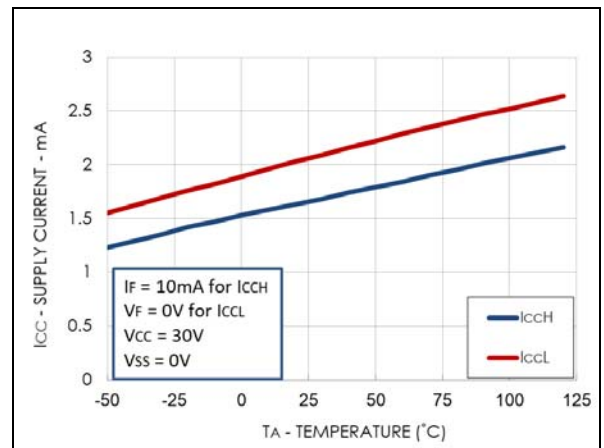

Fig.5 I_{CC} vs. V_{CC}

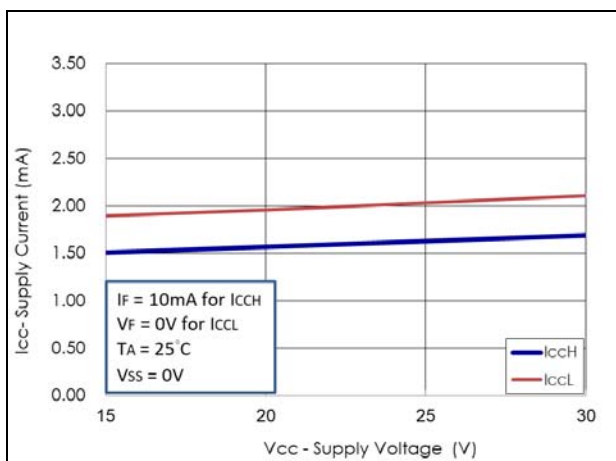

Fig.6 I_{FLH} vs. Hysteresis

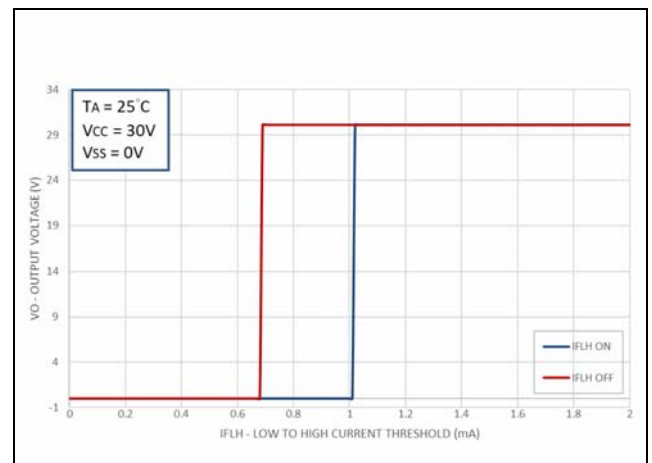

Fig.7 I_{FH} vs. Temperature

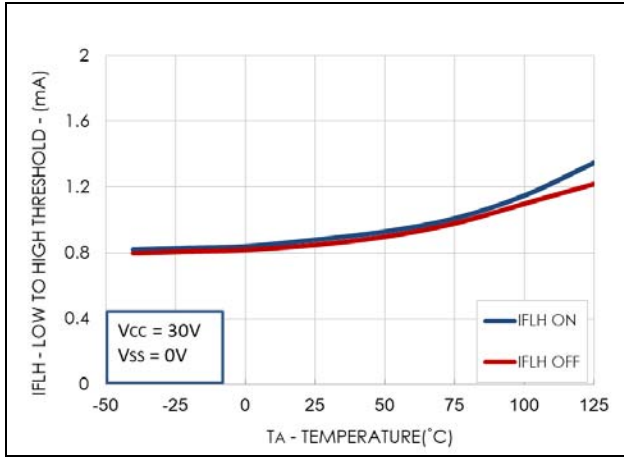

Fig.8 Propagation Delays vs. V_{CC}

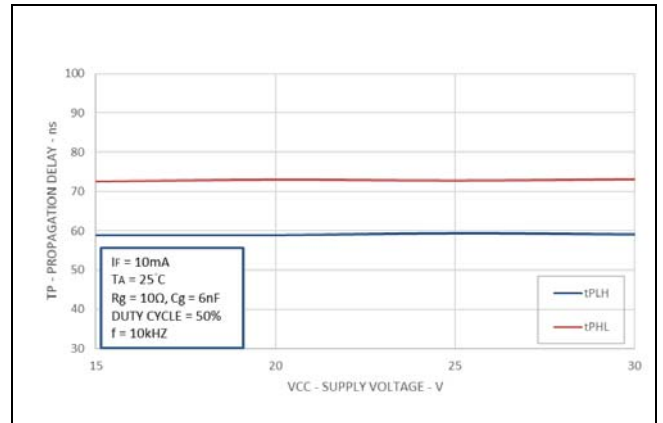

Fig.9 Propagation Delays vs. I_f

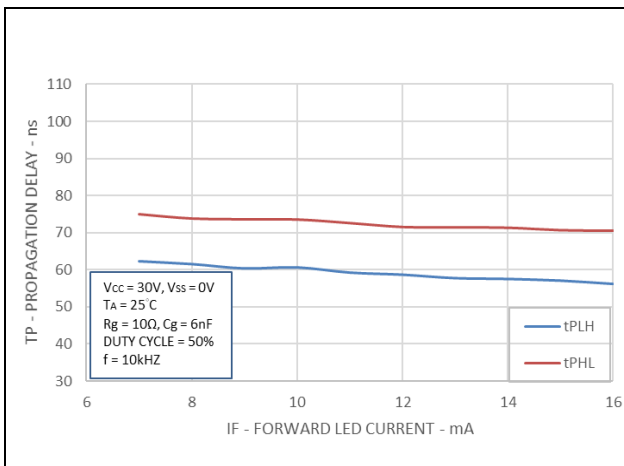

Fig.10 Propagation Delays vs. Temperature

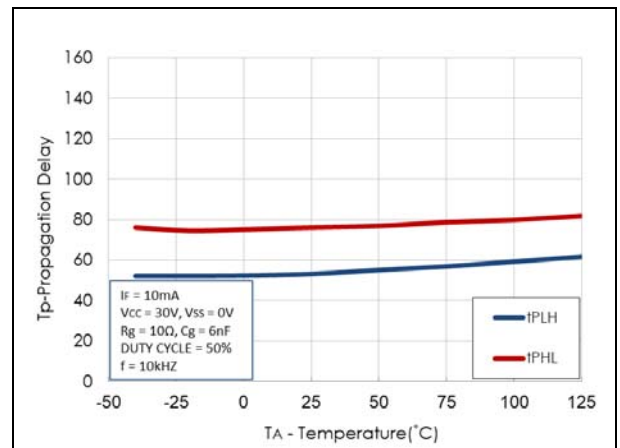

Fig.11 Propagation Delays vs. R_g

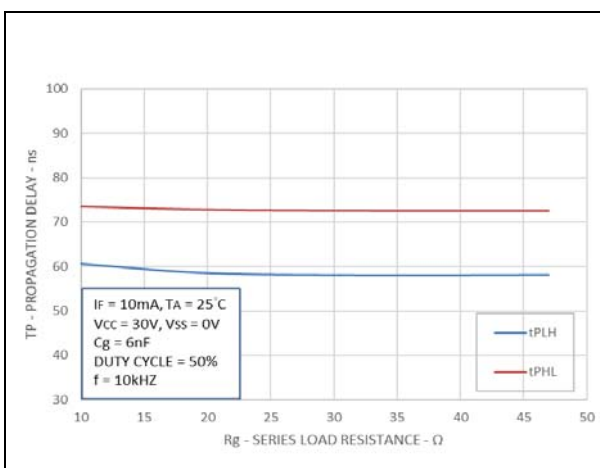

Fig.12 Propagation Delays vs. C_g

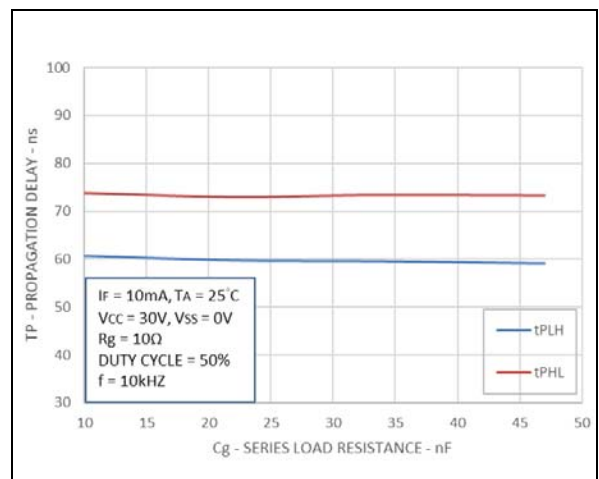
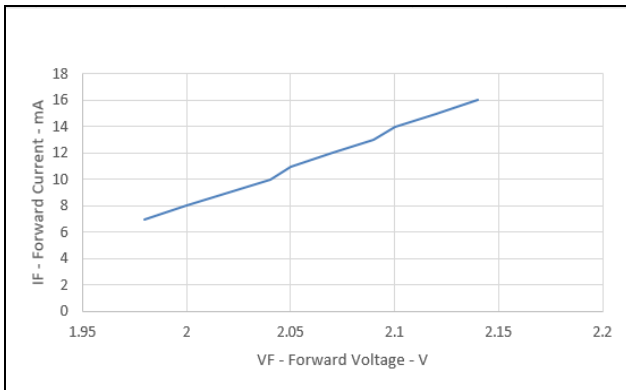
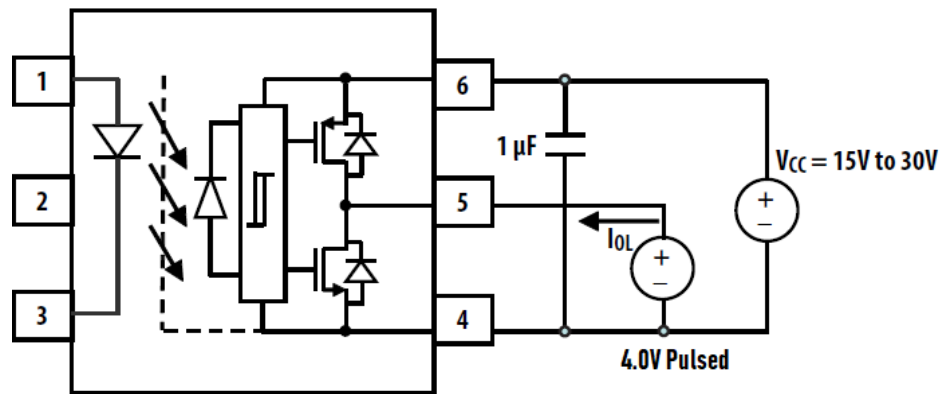

Fig.13 Input Current vs. Forward Voltage



● **Test Circuit**

1. **I_{OL} Measure**



2. **I_{OH} Measure**

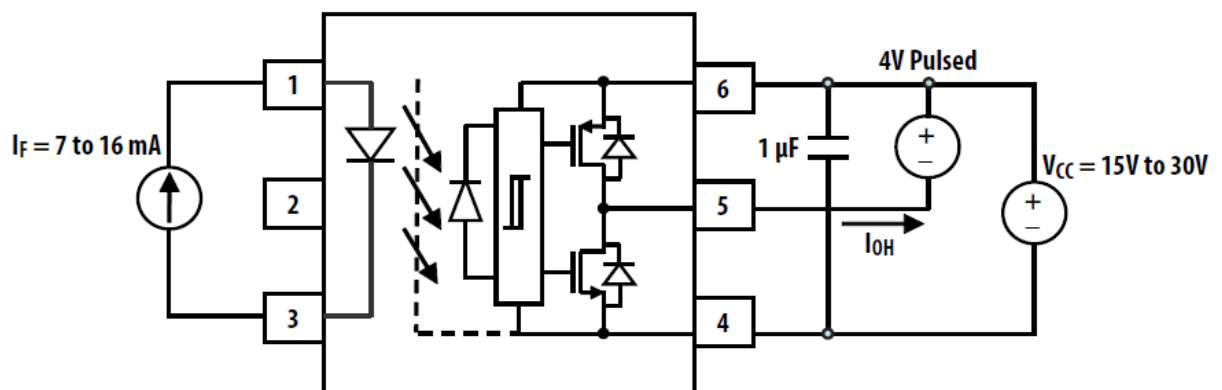

3. V_{OH} Measure

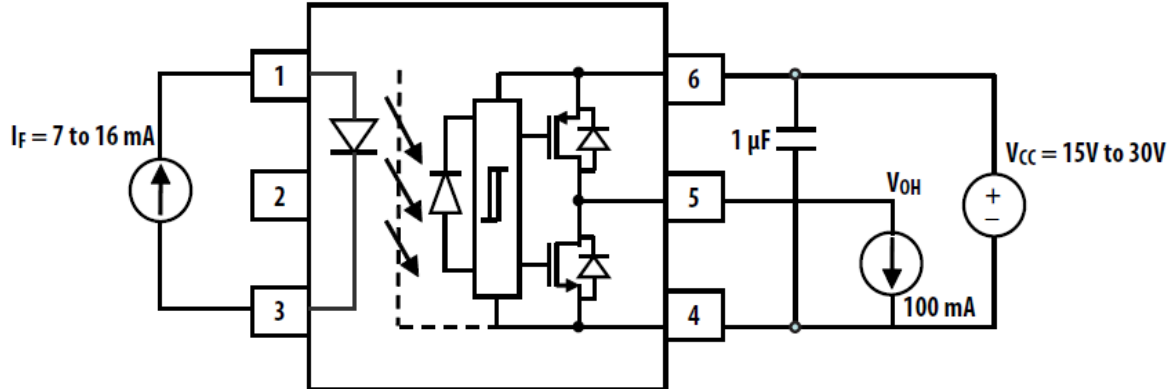

4. V_{OL} Measure

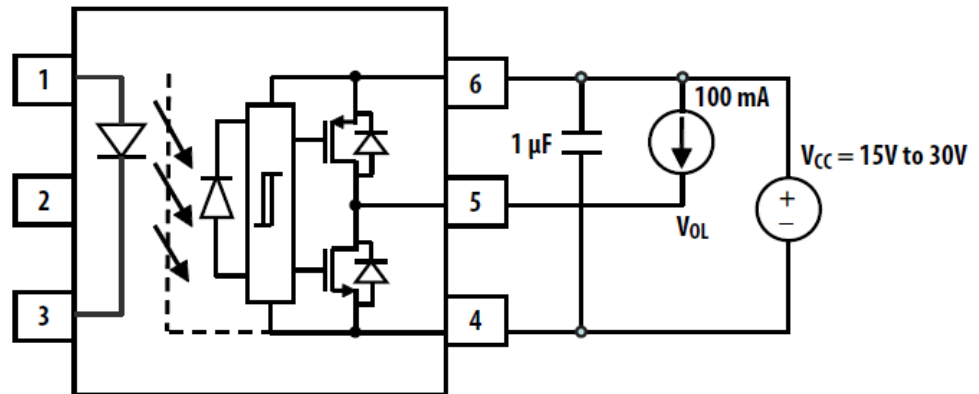

5. I_{FLH} Measure

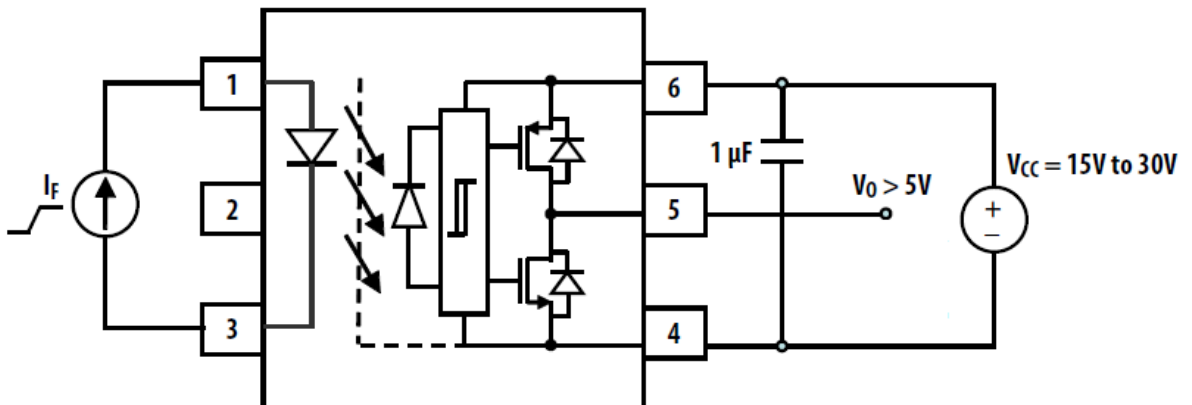

6. UVLO Measure

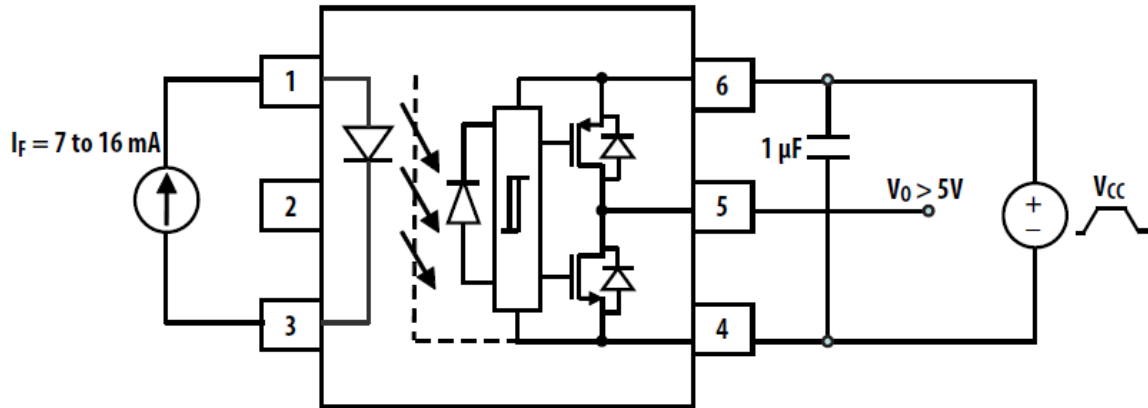

7. t_{PHL} , t_{PLH} , t_r and t_f Measure and Waveforms

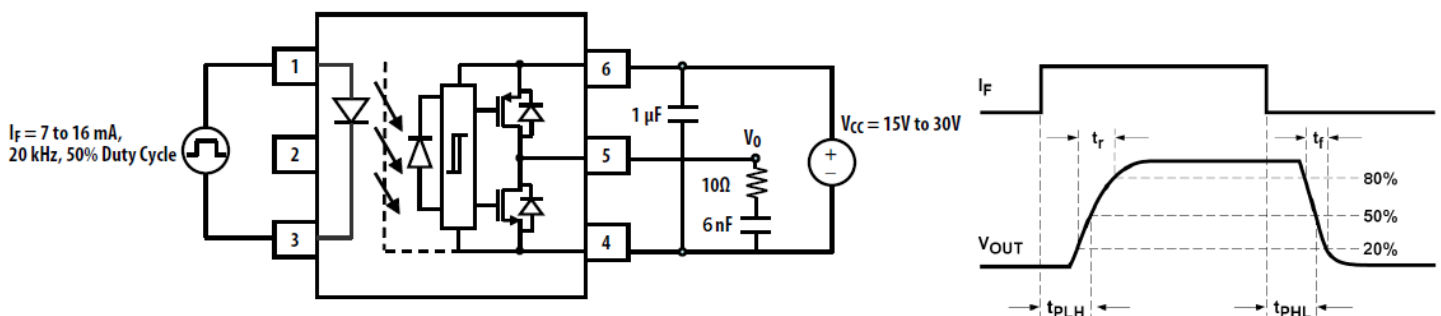

8. CMR Measure with Split Resistors Network and Waveforms

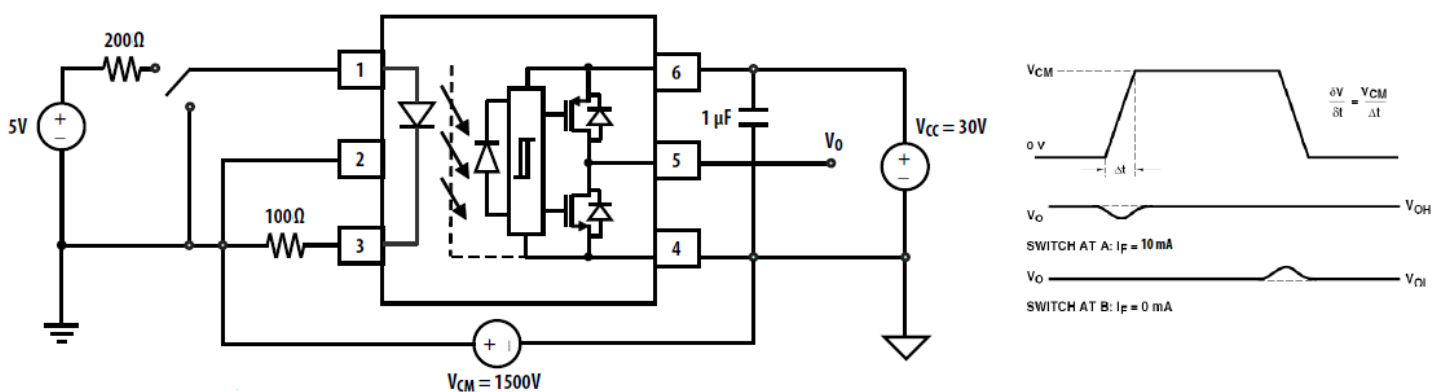

● **Recommended Soldering Conditions**

IR Reflow soldering : One time soldering reflow is recommended within the condition of temperature and time profile shown below. Do not solder more than three times.

Recommended Temperature Profile of Infrared Reflow

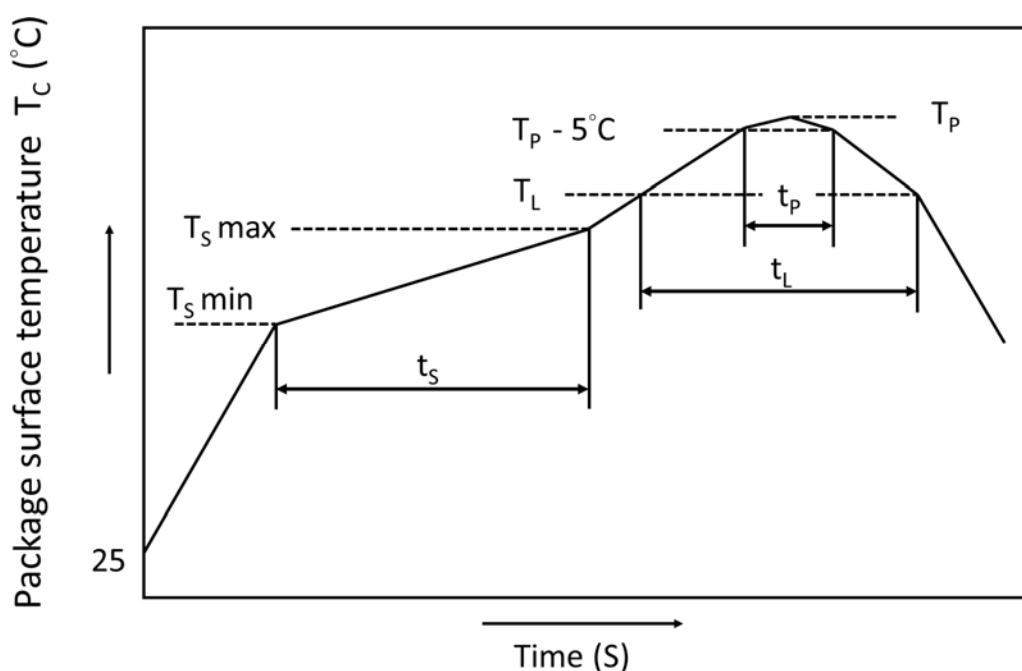

Profile Item	Symbol	Min.	Max.	Unit
Preheat temperature	T_S	150	200	°C
Preheat time	t_S	60	120	s
Ramp-up rate (T_L to T_P)	-	—	3	°C/s
Liquidus temperature	T_L	217		°C
Time above T_L	t_L	60	100	s
Peak Temperature	T_P	—	260	°C
Time during which T_C is between ($T_P - 5$) and T_P	t_p	—	20	s
Ramp-down rate	-	—	6	°C/s

- **Numbering System**

KT0341 X (Y)-(Z)

Notes:

KT0341 = Part No.

X = Lead form option (P · W)

Y = Tape and reel option (TLD · TRU)

Z = VDE option (V · None)

Option	Description	Packing quantity
P (TLD)	surface mount type package + TLD tape & reel option (9mm clearance)	3000 units per reel
P (TRU)	surface mount type package + TRU tape & reel option (9mm clearance)	3000 units per reel
W (TLD)	long creepage distance for surface mount type package + TLD tape & reel option (11mm clearance)	3000 units per reel
W (TRU)	long creepage distance for surface mount type package + TRU tape & reel option (11mm clearance)	3000 units per reel

- **Recommended Pad Layout for Surface Mount Lead Form**

1. Surface mount type

6LSOP-P type

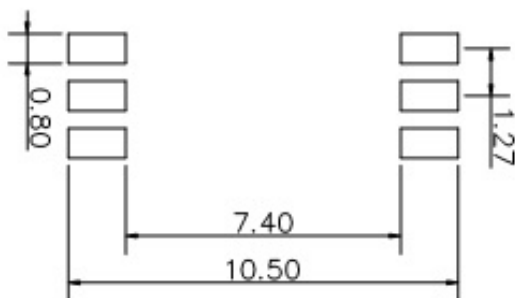
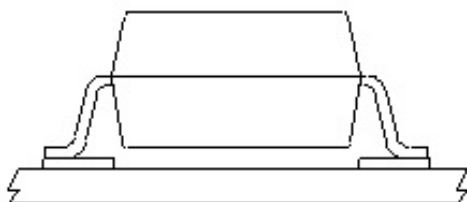

2. Long creepage distance for surface mount type

6LSOP-W type

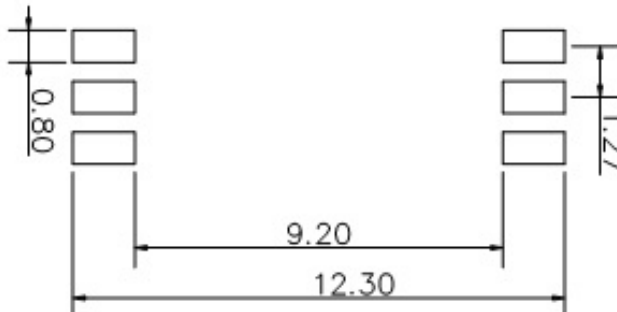
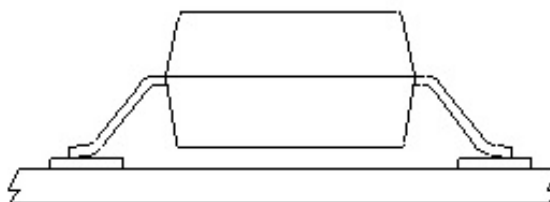

Unit :mm

● LSOP6 Carrier Tape & Reel

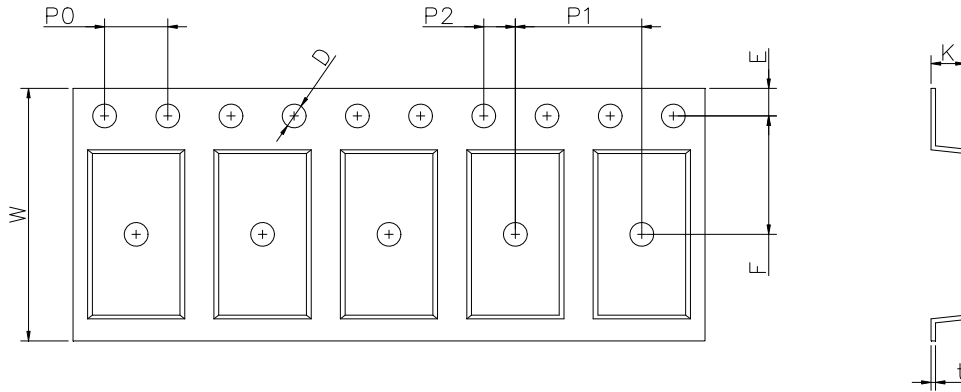

Dimension Symbol	D	E	F	P0	P1	P2	t	W	K
P type Dimension (mm)	1.5±0.1	1.75±0.1	7.5±0.1	4.0±0.1	8.0±0.1	2.0±0.1	0.3±0.1	16.0±0.3	2.15±0.1
W type Dimension (mm)	1.5±0.1	1.75±0.1	11.5±0.1	4.0±0.1	8.0±0.1	2.0±0.1	0.3±0.1	24.0±0.3	2.52±0.1

TRU

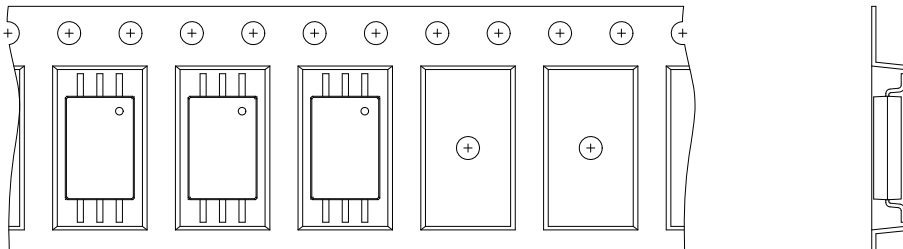

TLD

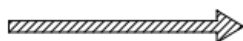
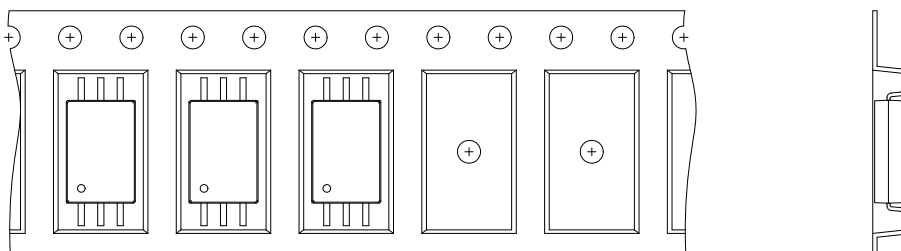

Direction of feed from reel

- **Application Notice**

The statements regarding the suitability of products for certain types of applications are based on cosmo's knowledge of general applications of cosmo products. Such statements are not binding statements about the suitability of products for a particular application. It is the customer's responsibility to verify the specifications are suitable for use in a particular application. Customers are solely responsible for all aspects of their own product design or applications. The parameters provided in the datasheet may vary in different applications and performance may vary over time. All operating parameters (including typical parameters) must be validated by customer's technical experts for different applications. cosmo assumes no liability for customer' product design or applications. Product specifications do not expand or otherwise change cosmo's terms and conditions of purchase, including but not limited to the warranty expressed therein.

When using cosmo products, please comply with safety standards and instructions. cosmo has no liability and responsibility to the damage caused by improper use of the instructions specified in the specifications.

cosmo products are designed for use in general electronic equipment such as telecommunications, office automation equipments, personal computers, test and measurement equipments, consumer electronics, industrial control, instrumentation, audio, video.

cosmo devices shall not be used in equipment that requires higher level of reliability and safety, such as nuclear power control equipment, telecommunication equipment(trunk lines), space application, medical and other life supporting equipments, and equipment for aircraft, military, automotive or any other application that can cause human injury or death.

cosmo reserves the right to change the specifications, data, characteristics, structure, materials and other contents at any time without notice. Please contact cosmo to obtain the latest specification.

cosmo disclaim any and all liability for any errors, inaccuracies or incompleteness contained in any datasheet or in any other disclosure relating to any product.