

● Description

The KT1400 series consist of a photodarlington optically coupled to a gallium arsenide infrared-emitting diode in a 4 pin LSOP wide body package. Collector-emitter voltage is 300V. It features a high current transfer ratio, low coupling capacitance and high isolation voltage.

● Schematic

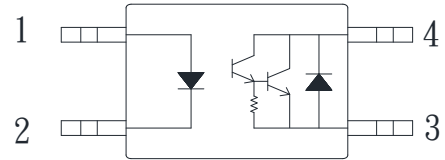

1. Anode
2. Cathode
3. Emitter
4. Collector

● Features

1. Pb free and RoHS compliant
2. Opaque type, SMD low profile 4 lead package
3. High collector-emitter voltage ($V_{CE0} : 300V$)
4. High current transfer ratio
(CTR : Min.1000% at $I_F = 1mA, V_{CE} = 2V$)
5. High isolation voltage 5000Vrms
6. 8mm outer creepage distance
7. MSL class 1
8. Agency Approvals:
 - UL Approved (No. E169586): UL1577
 - c-UL Approved (No. E169586)
 - VDE Approved (No. 40031267): DIN EN60747-5-5
 - FIMKO Approved EN62368-1, EN60601-1
 - CQC Approved: GB8898-2011, GB4943.1-2011

● Applications

- Telephone sets
- Copiers, facsimiles
- Interfaces with various power supply circuits, power distribution boards
- Hybrid substrates which require high density mounting

● **Outside Dimension**

Unit : mm

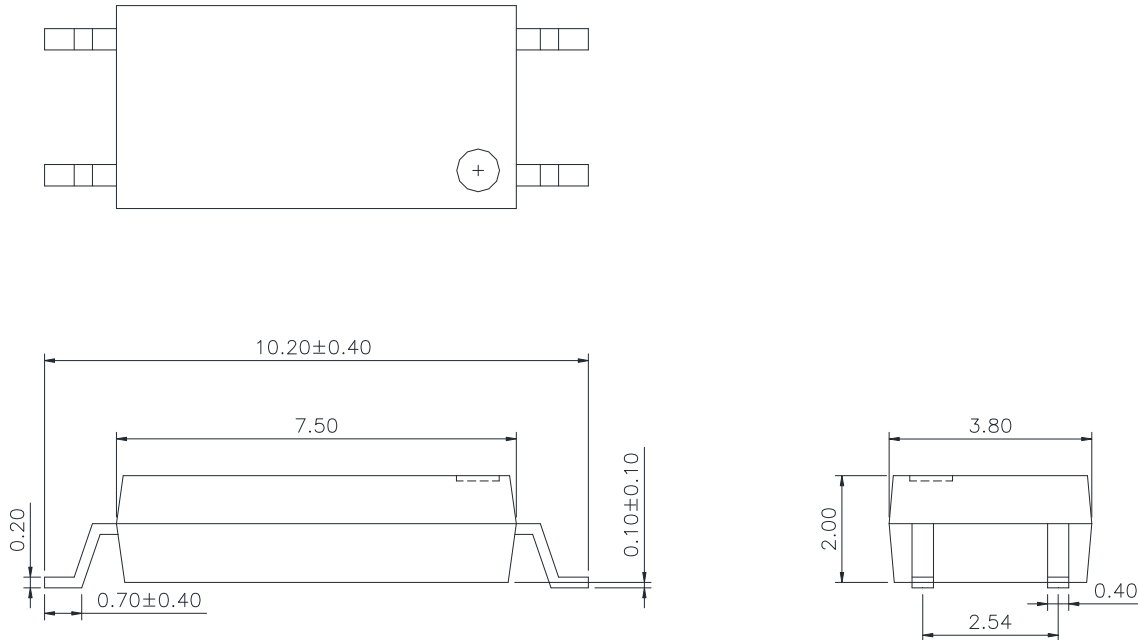

TOLERANCE : $\pm 0.2\text{mm}$

● **Device Marking**

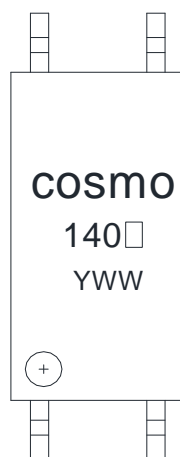

Notes:

cosmo

140□

YWW

□: CTR rank

Y: Year code / WW: Week code



KT1400 Series

4PIN LSOP PHOTODARLINGTON PHOTOCOUPLER

● Absolute Maximum Ratings

(Ta=25°C)

Parameter		Symbol	Rating	Unit
Input	Forward current	I _F	50	mA
	Peak forward current	I _{FP}	1	A
	Reverse voltage	V _R	6	V
	Power dissipation	PD	70	mW
Output	Collector-Emitter voltage	V _{CEO}	300	V
	Emitter-Collector voltage	V _{ECO}	0.1	V
	Collector current	I _C	150	mA
	Collector power dissipation	P _C	150	mW
Total power dissipation		P _{tot}	170	mW
Isolation voltage 1 minute		V _{iso}	5000	V _{rms}
Operating temperature		T _{opr}	-55 to +100	°C
Storage temperature		T _{stg}	-55 to +125	°C
Soldering temperature 10 second		T _{sol}	260	°C

● Electro-optical Characteristics

(Ta=25°C)

Parameter		Symbol	Conditions	Min.	Typ.	Max.	Unit
Input	Forward voltage	V _F	I _F =20mA	-	1.2	1.4	V
	Reverse current	I _R	V _R =4V	-	-	10	uA
	Terminal capacitance	C _t	V=0, f=1KHz	-	30	-	pF
Output	Collector dark current	I _{CEO}	V _{CE} =200V, I _F =0	-	-	1	uA
	Collector-Emitter breakdown voltage	BV _{CEO}	I _C =0.1mA, I _F =0	300	-	-	V
Transfer characteristics	Current transfer ratio	CTR	I _F =1mA, V _{CE} =2V	1000	-	-	%
	Collector-Emitter saturation voltage	V _{CE(sat)}	I _F =1mA, I _C =2mA	-	-	1.5	V
	Isolation resistance	R _{iso}	DC500V, 40 to 60%RH	5x10 ¹⁰	10 ¹¹	-	Ω
	Floating capacitance	C _f	V=0, f=1MHz	-	0.6	1.0	pF
	Response time (Rise)	t _r	V _{CC} =2V, I _C =20mA, R _L =100Ω	-	100	300	us
Response time (Fall)	t _f	-		20	100	us	

Classification table of current transfer ratio is shown below.

CTR Rank	CTR (%)
KT1400	Min.1000

Fig.1 Current Transfer Ratio vs. Forward Current

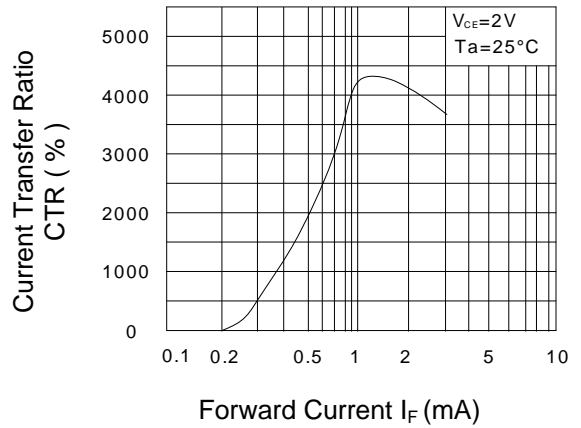

Fig.2 Collector Power Dissipation vs. Ambient Temperature

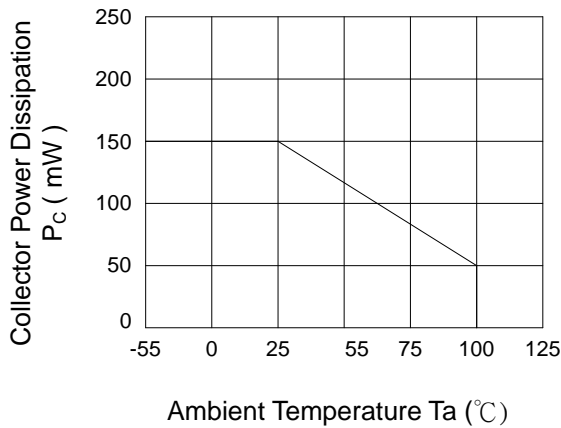

Fig.3 Collector Dark Current vs. Ambient Temperature

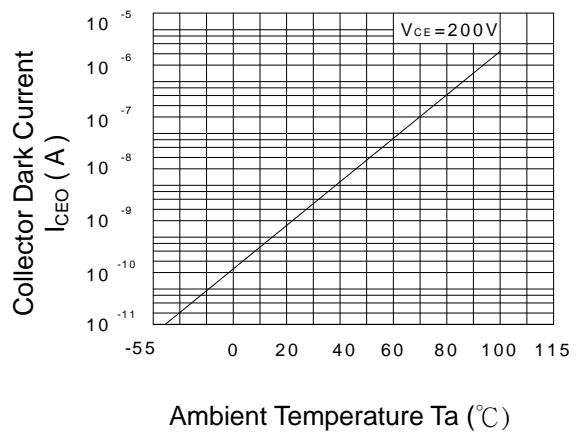

Fig.4 Forward Current vs. Ambient Temperature

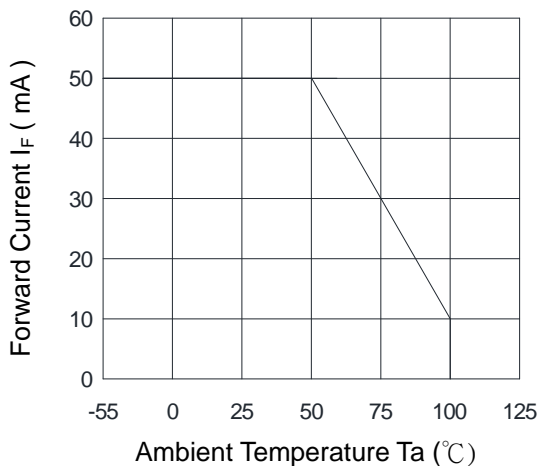

Fig.5 Forward Current vs. Forward Voltage

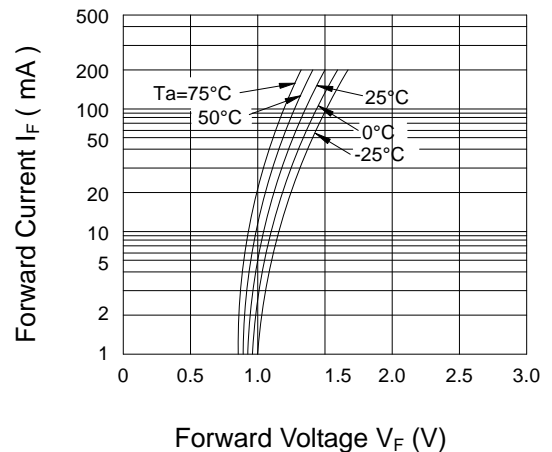

Fig.6 Collector Current vs. Collector-Emitter Voltage

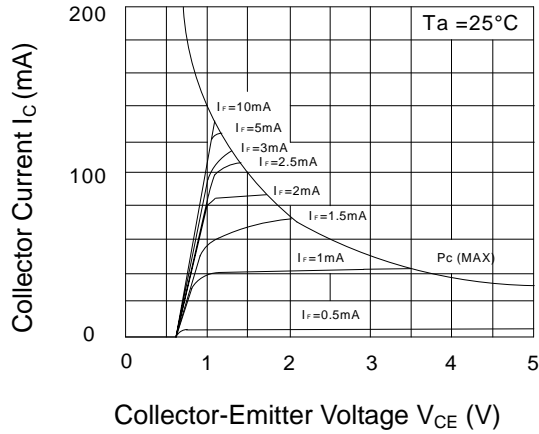

Fig.7 Relative Current Transfer Ratio vs. Ambient Temperature

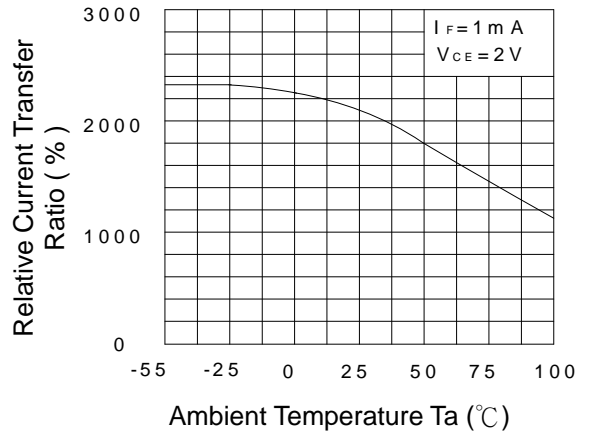

Fig.8 Collector-Emitter Saturation Voltage vs. Forward Current

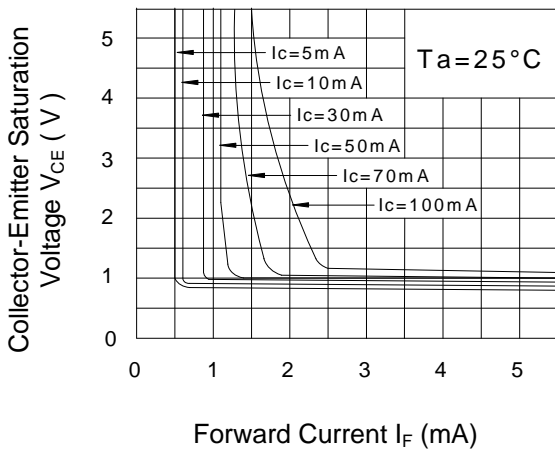
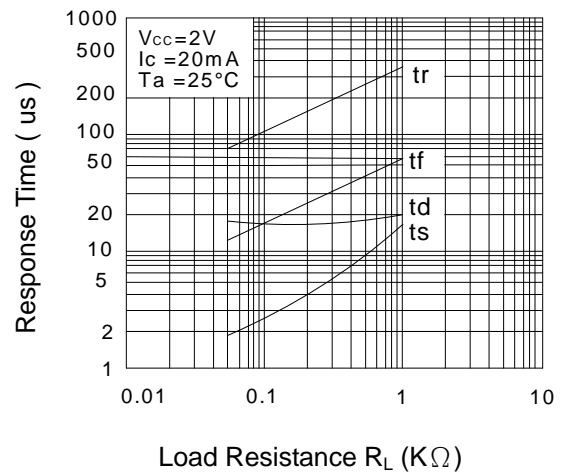
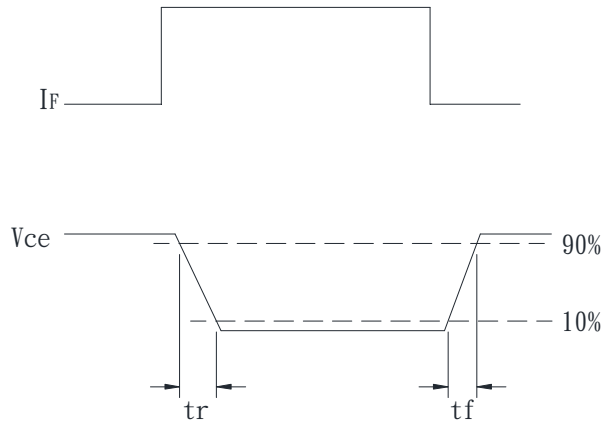
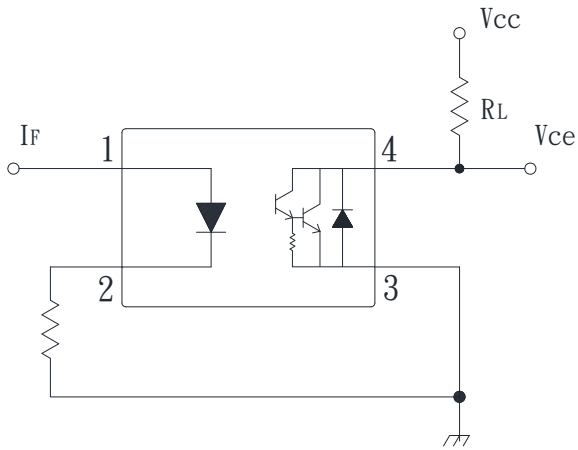

Fig.9 Response Time vs. Load Resistance



● **Test Circuit for Response Time**



● Recommended Soldering Conditions

(a) Infrared reflow soldering :

- Peak reflow soldering : 260°C or below (package surface temperature)
- Time of peak reflow temperature : 10 sec
- Time of temperature higher than 230°C : 30-60 sec
- Time to preheat temperature from 180~190°C : 60-120 sec
- Time(s) of reflow : Two
- Flux : Rosin flux containing small amount of chlorine (The flux with a maximum chlorine content of 0.2 Wt% is recommended.)

Recommended Temperature Profile of Infrared Reflow

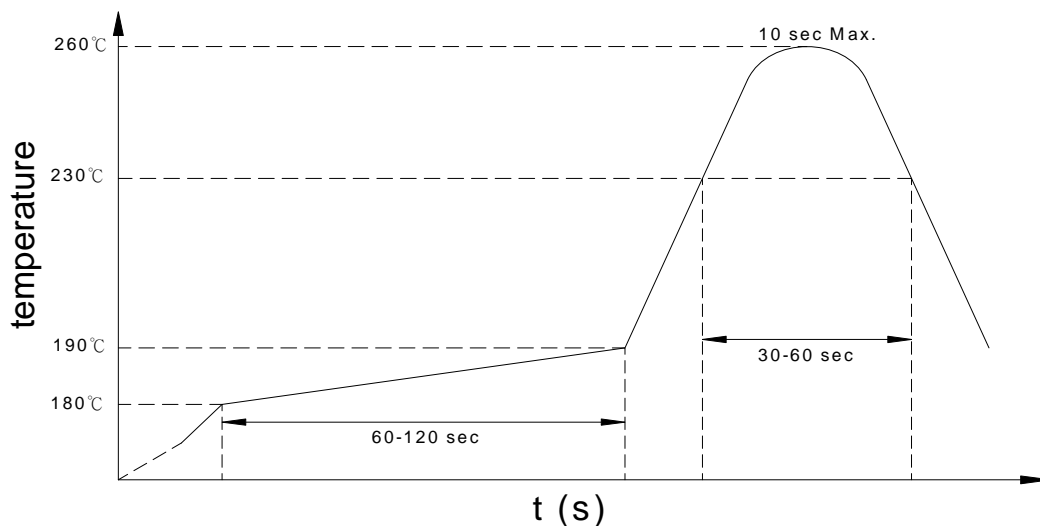

(b) Wave soldering :

- Temperature : 260°C or below (molten solder temperature)
- Time : 10 seconds or less
- Preheating conditions : 120°C or below (package surface temperature)
- Time(s) of reflow : One
- Flux : Rosin flux containing small amount of chlorine (The flux with a maximum chlorine content of 0.2 Wt% is recommended.)

(c) Cautions :

- Fluxes : Avoid removing the residual flux with freon-based and chlorine-based cleaning solvent.
- Avoid shorting between portion of frame and leads.

- **Numbering System**

KT1400 (Z)

Notes:

KT1400= Part No.

Z = Tape and reel option (TLD ∙ TRU)

Option	Description	Packing quantity
(TLD)	TLD tape & reel option	3000 units per reel
(TRU)	TRU tape & reel option	3000 units per reel

- **Recommended Pad Layout for Surface Mount Lead Form**

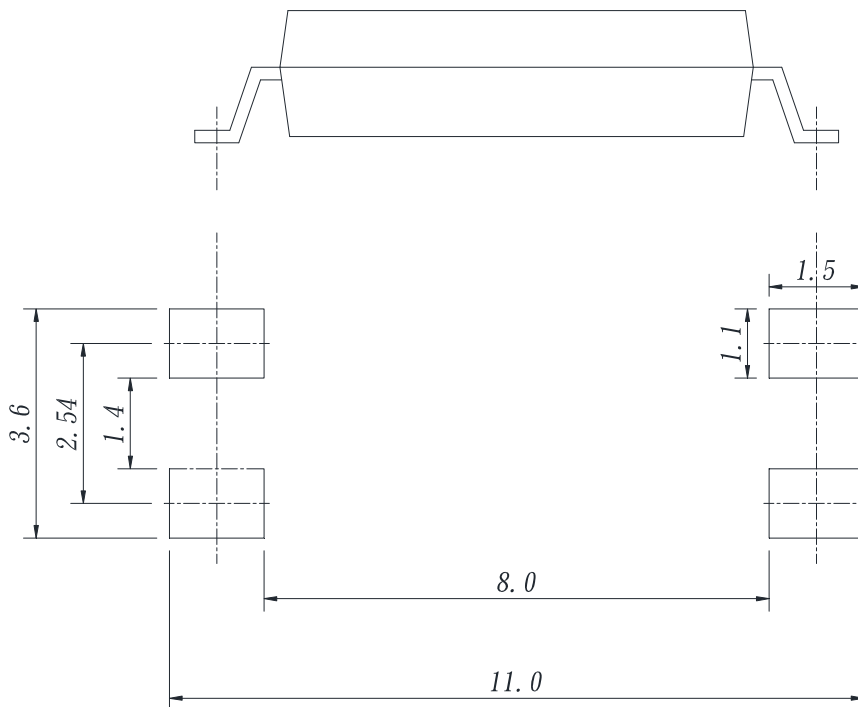

Unit : mm

● 4-pin LSOP Carrier Tape & Reel

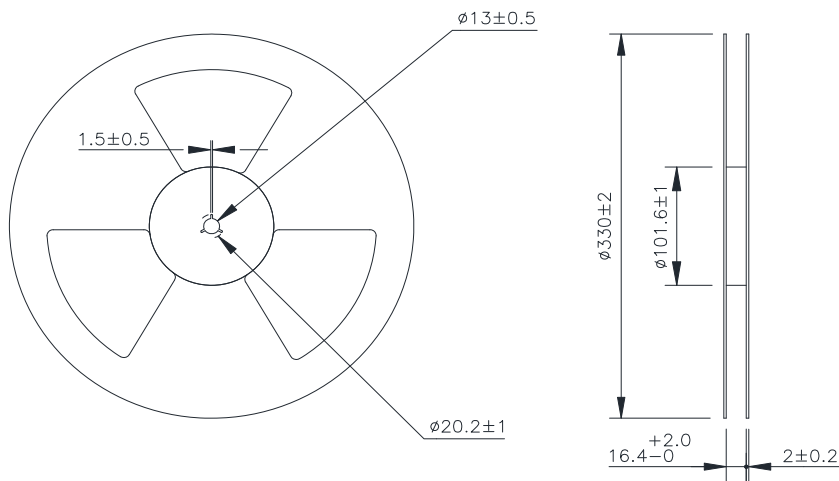
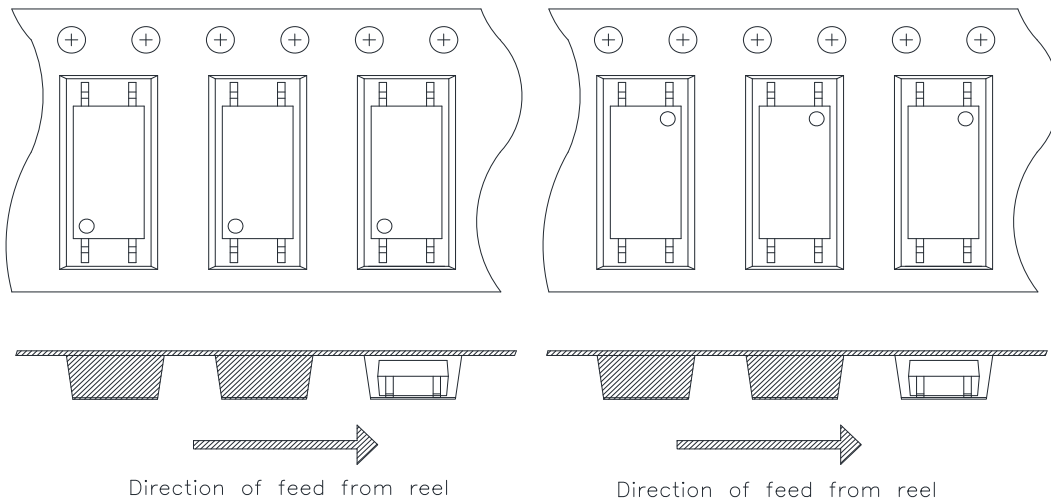
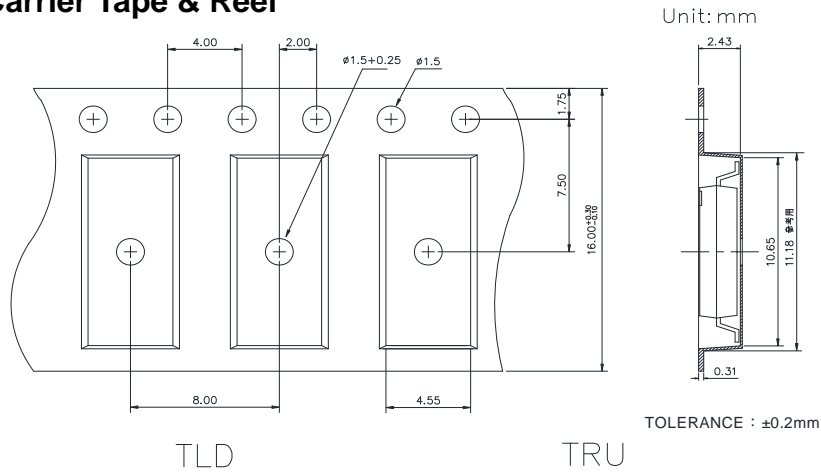

- **Application Notice**

The statements regarding the suitability of products for certain types of applications are based on cosmo's knowledge of general applications of cosmo products. Such statements are not binding statements about the suitability of products for a particular application. It is the customer's responsibility to verify the specifications are suitable for use in a particular application. Customers are solely responsible for all aspects of their own product design or applications. The parameters provided in the datasheet may vary in different applications and performance may vary over time. All operating parameters (including typical parameters) must be validated by customer's technical experts for different applications. cosmo assumes no liability for customer' product design or applications. Product specifications do not expand or otherwise change cosmo's terms and conditions of purchase, including but not limited to the warranty expressed therein.

When using cosmo products, please comply with safety standards and instructions. cosmo has no liability and responsibility to the damage caused by improper use of the instructions specified in the specifications.

cosmo products are designed for use in general electronic equipment such as telecommunications, office automation equipments, personal computers, test and measurement equipments, consumer electronics, industrial control, instrumentation, audio, video.

cosmo devices shall not be used in equipment that requires higher level of reliability and safety, such as nuclear power control equipment, telecommunication equipment(trunk lines), space application, medical and other life supporting equipments, and equipment for aircraft, military, automotive or any other application that can cause human injury or death.

cosmo reserves the right to change the specifications, data, characteristics, structure, materials and other contents at any time without notice. Please contact cosmo to obtain the latest specification.

cosmo disclaim any and all liability for any errors, inaccuracies or incompleteness contained in any datasheet or in any other disclosure relating to any product.